

Refrigerating air dryer

ACT 20 – 500

Air – water cooled

EN - User's maintenance and spare parts manual

Dear Customer,

thank you for choosing our product. In order to get the best performances out of this product, please read this manual carefully.

To avoid incorrect operation of the equipment and possible physical risk to the operator, please read and strictly follow the instructions contained in this manual.

Note, these instructions are in addition to the safety rules that apply in the country where the dryer is installed.

Before packing for shipment each **ACT** series refrigerated air dryer undergoes a rigorous test to ensure the absence of any manufacturing faults and to demonstrate that the device can perform all the functions for which it has been designed.

Once the dryer has been properly installed according to the instructions in this manual, it will be ready for use without any further adjustment. The operation is fully automatic, and the maintenance is limited to few controls and some cleaning operations, as detailed in the following chapters.

This manual must be maintained available in any moment for future references and it has to be intended as inherent part of the relevant dryer.

Due to the continuous technical evolution, we reserve the right to introduce any necessary change without giving previous notice.

Should you experience any trouble, or for further information, please do not hesitate to contact us.

Contents

1	Identification plate	5
2	Warranty conditions	5
3	Safety rules	5
3.1	Definition of the conventional signs used in this manual	5
3.2	Warnings	6
3.3	Proper use of the dryer	6
3.4	Instructions for the use of pressure equipment according to PED directive 2014/68/EU	7
4	Installation	7
4.1	Transport	7
4.2	Storage	7
4.3	Installation site	8
4.4	Installation layout	9
4.5	Correction factors	10
4.6	Connection to the compressed air system	11
4.7	Connection to the cooling water network (Water-Cooled)	11
4.8	Electrical connections	12
4.9	Condensate drain	12
5	Start-up	13
5.1	Preliminary operation	13
5.2	First start-up	13
5.3	Start-up and shut down	14
6	Technical data	15
6.1	Technical data ACT 20 – 200 1/115/60	15
6.2	Technical data ACT 20 – 500 1/230/60	16
6.3	Technical data ACT 200 – 500 3phase 3/460/60	17
6.4	Technical data ACT 200 – 500 3phase 3/575/60	18
7	Technical description	19
7.1	Control panel	19
7.2	Operation	19
7.3	Flow diagram (Air-Cooled)	20
7.4	Flow diagram (Water-Cooled)	20
7.5	Refrigerating compressor	21
7.6	Condenser (Air-Cooled)	21
7.7	Condenser (Water-Cooled)	21
7.8	Condenser water regulating valve (Water-Cooled)	21
7.9	Filter dryer	21
7.10	Capillary tube	21
7.11	Alu-Dry module	22
7.12	Hot gas by-pass valve	22
7.13	Refrigerant pressure switches LPS – HPS	22
7.14	Safety thermo switch TS	22
7.15	Compressor crankcase heater	23
7.16	Electronic instrument DMC34	23
7.16.1	How to switch on the dryer	23
7.16.2	How to switch off the dryer	23
7.16.3	How to display the operating parameters	23
7.16.4	How a service warning / alarm is displayed	24
7.16.5	How is controlled the condenser FAN	24
7.16.6	How is controlled the drain solenoid valve	24
7.16.7	How to reset the service reminder timer	24
7.16.8	Operation of the failure / alarm dry contact	24
7.16.9	How to change the operating parameters – SETUP menu	25
7.17	Electronic drainer (optional)	26
8	Maintenance, troubleshooting, spare parts and dismantling	27
8.1	Checks and maintenance	27
8.2	Troubleshooting	28
8.3	Spare parts	31
8.4	Maintenance operation on the refrigeration circuit	32
8.5	Dismantling of the dryer	32

9	Attachments	33
	Exploded views – List of components	33
	Electric diagrams – List of components	33
9.1	Dryers dimensions	34
9.1.1	ACT 20 – 50	34
9.1.2	ACT 75	35
9.1.3	ACT 100 – 150	36
9.1.4	ACT 200 – 250	37
9.1.5	ACT 300 – 350	38
9.1.6	ACT 400 – 500	39
9.1.7	ACT 200 – 250 3phase	40
9.1.8	ACT 300 – 350 3phase	41
9.1.9	ACT 400 – 500 3phase	42
9.2	Exploded views	43
9.2.1	ACT 20 – 30	43
9.2.2	ACT 50	44
9.2.3	ACT 75	45
9.2.4	ACT 100	46
9.2.5	ACT 125 – 150	47
9.2.6	ACT 200 – 250 Air Cooled	48
9.2.7	ACT 200 – 250 Water Cooled	49
9.2.8	ACT 300 – 350 Air Cooled	50
9.2.9	ACT 300 – 350 Water Cooled	51
9.2.10	ACT 400 – 500 Air Cooled	52
9.2.11	ACT 400 – 500 Water Cooled	53
9.2.12	ACT 200 – 250 3phase Air Cooled	54
9.2.13	ACT 200 – 250 3phase Water Cooled	55
9.2.14	ACT 300 – 350 3phase Air Cooled	56
9.2.15	ACT 300 – 350 3phase Water Cooled	57
9.2.16	ACT 400 – 500 3phase Air Cooled	58
9.2.17	ACT 400 – 500 3phase Water Cooled	59
9.3	Electric diagrams	60
9.3.1	ACT 20 – 100	60
9.3.2	ACT 125 – 250	61
9.3.3	ACT 300 – 500	62
9.3.4	ACT 200 – 500 3phase Sheet 1 of 3	63
9.3.5	ACT 200 – 500 3phase Sheet 2 of 3	64
9.3.6	ACT 200 – 500 3phase Sheet 3 of 3	65
10	Blank pages	66

1 Identification plate

The identification plate is located on the back of the dryer and shows all the primary data of the machine. This data should always be referred to when calling the manufacturer or distributor. The removal or alteration of the identification plate will void the warranty rights.

2 Warranty conditions

For 12 months from the installation date, but no longer than 14 months from the delivery date, the warranty covers eventual faulty parts, which will be repaired or replaced free of charge, except the travel, hotel and restaurant expenses of our engineer.

The warranty doesn't cover any responsibility for direct or indirect damages to persons, animals or equipment caused by improper usage or maintenance, and it's limited to manufacturing faults only.

The right to warranty repairs is subordinated to the strict compliance with the installation, use and maintenance instructions contained in this manual.

The warranty will be immediately voided in case of even small changes or alterations to the dryer. To require repairs during the warranty period, the data reported on the identification plate must be notified.

3 Safety rules

3.1 Definition of the conventional signs used in this manual



Carefully read instruction manual before attempting any service or maintenance procedures on the dryer.



Caution warning sign. Risk of danger or possibility of damage to equipment, if related text is not followed properly.



Electrical hazard. Warning message indicates practices or procedures that could result in personal injury or fatality if not followed correctly.



Danger hazard. Part or system under pressure.



Danger hazard. High temperature conditions exist during operation of system. Avoid contact until system or component has dissipated heat.



Danger hazard. Treated air is not suitable for breathing purposes; serious injury or fatality may result if precautions are not followed.



Danger hazard: In case of fire, use an approved fire extinguisher, water is not an acceptable means in cases of fire.



Danger hazard. Do not operate equipment with panels removed.



Maintenance or control operation to be performed by qualified personnel only [1].



Compressed air inlet connection point



Compressed air outlet connection point



Condensate drain connection point



Cooling water inlet connection point (Water-Cooled)



Cooling water outlet connection point (Water-Cooled)



Operations which can be performed by the operator of the machine, if qualified [1].

NOTE: Text that specifies items of note to be taken into account does not involve safety precautions.



In designing this unit a lot of care has been devoted to environmental protection:

- CFC free refrigerants
- CFC free insulation parts
- Energy saving design
- Limited acoustic emission
- Dryer and relevant packaging composed of recyclable materials

This symbol requests that the user heed environmental considerations and abide with suggestions annotated with this symbol.

[1] Experienced and trained personnel familiar with national and local codes, capable to perform the needed activities, identify and avoid possible dangerous situations while handling, installing, using and servicing the machine. Ensuring compliance to all statutory regulations.

3.2 Warnings



Compressed air is a highly hazardous energy source.

Never work on the dryer with pressure in the system.

Never point the compressed air or the condensate drain outlet hoses towards anybody.



The user is responsible for the proper installation of the dryer. Failure to follow instructions given in the "Installation" chapter will void the warranty. Improper installation can create dangerous situations for personnel and/or damages to the machine could occur.



Only qualified personnel are authorized to service electrically powered devices. Before attempting maintenance, the following conditions must be satisfied:

- Ensure that main power is off, machine is locked out, tagged for service and power cannot be restored during service operations.
- Ensure that valves are shut and the air circuit is at atmospheric pressure. De-pressurize the dryer.



These refrigerating air dryers contain R134a or R407C HFC type refrigerant fluid. Refer to the specific paragraph - maintenance operation on the refrigerating circuit.



Warranty does not apply to any unit damaged by accident, modification, misuse, negligence or misapplication. Unauthorized alterations will immediately void the warranty.



In case of fire, use an approved fire extinguisher, water is not an acceptable means in cases of electrical fire.

3.3 Proper use of the dryer

This dryer has been designed, manufactured and tested for the purpose of separating the humidity normally contained in compressed air. Any other use has to be considered improper.

The Manufacturer will not be responsible for any problem arising from improper use; the user will bear responsibility for any resulting damage.

Moreover, the correct use requires the adherence to the installation instructions, specifically:

- Voltage and frequency of the main power.
- Pressure, temperature and flow-rate of the inlet air.
- Pressure, temperature and cooling water capacity (Water-Cooled).
- Ambient temperature.

This dryer is supplied tested and fully assembled. The only operation left to the user is the connection to the plant in compliance with the instructions given in the following chapters.



The purpose of the machine is the separation of water and eventual oil particles present in compressed air.



The dried air cannot be used for breathing purposes or for operations leading to direct contact with foodstuff.

This dryer is not suitable for the treatment of dirty air or of air containing solid particles.

3.4 Instructions for the use of pressure equipment according to PED directive 2014/68/EU

To ensure the safe operation of pressure equipments, the user must conform strictly to the above directive and the following:

1. The equipment must only be operated within the temperature and pressure limits stated on the manufacturer's data nameplate.
2. Welding on heat-exchanger is not recommended.
3. The equipment must not be stored in badly ventilated spaces, near a heat source or inflammable substances.
4. Vibration must be eliminated from the equipment to prevent fatigue failure.
5. Automatic condensate drains should be checked for operation every day to prevent a build up of condensate in the pressure equipment.
6. The maximum working pressure stated on the manufacturer's data nameplate must not be exceeded. Prior to use, the user must fit safety / pressure relief devices.
7. All documentation supplied with the equipment (manual, declaration of conformity etc.) must be kept for future reference.
8. Do not apply weights or external loads on the vessel or its connecting piping.



TAMPERING, MODIFICATION AND IMPROPER USE OF THE PRESSURE EQUIPMENT ARE FORBIDDEN. Users of the equipment must comply with all local and national pressure equipment legislation in the country of installation.

4 Installation

4.1 Transport

Check for visible loss or damage, if no visible damage is found place the unit near to the installation point and unpack the contents.

- To move the packaged unit we recommend using a suitable trolley or forklift truck. Hand carrying is not recommended.
- Always keep the dryer in the upright vertical position. Damage to components could result if unit is laid on its side or if placed upside down.
- Handle with care. Heavy blows could cause irreparable damage.

4.2 Storage

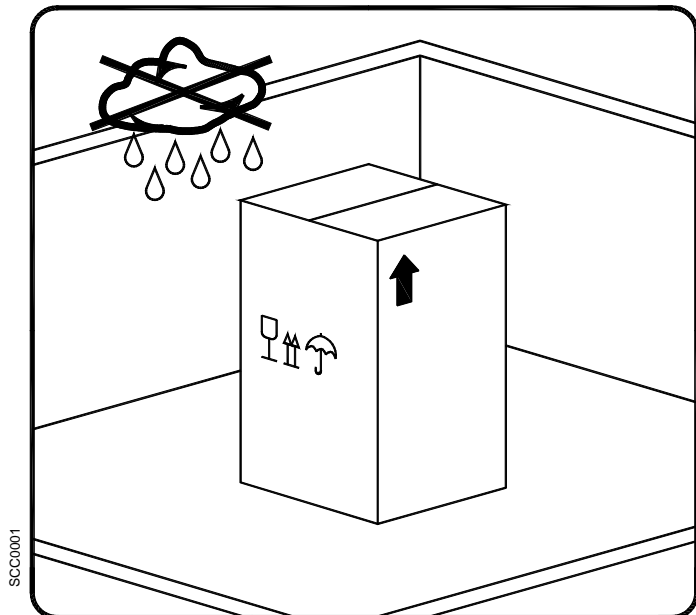

Even when packaged, keep the machine protected from severity of the weather.

Keep the dryer in vertical position, also when stored. Turning it upside down some parts could be irreparably damaged.

If not in use, the dryer can be stored in its packaging in a dust free and protected site at a maximum temperature of 122°F (50°C), and a specific humidity not exceeding 90%. Should the stocking time exceed 12 months, please contact the manufacturer.



The packaging materials are recyclable. Dispose of material in compliance with the rules and regulations in force in the destination country.

4.3 Installation site



Failure to install dryer in the proper ambient conditions will affect the dryer's ability to condense refrigerant gas. This can cause higher loads on the compressor, loss of dryer efficiency and performance, overheated condenser fan motors, electrical component failure and dryer failure due to the following: compressor loss, fan motor failure and electrical component failure. Failures of this type will affect warranty considerations.

Do not install dryer in an environment of corrosive chemicals, explosive gasses, poisonous gasses; steam heat, areas of high ambient conditions or extreme dust and dirt.



In case of fire, use an approved fire extinguisher, water is not an acceptable means in cases of fire.

Minimum installation requirements:

- Select a clean dry area, free from dust, and protected from atmospheric disturbances.
- The supporting area must be smooth, horizontal and able to hold the weight of the dryer.
- Minimum ambient temperature +34°F (+1°C).
- Maximum ambient temperature +122°F (+50°C).
- Ensure a proper cooling air replacement.
- Allow a sufficient clearance on each side of the dryer for proper ventilation and to facilitate maintenance operations.

The dryer does not require attachment to the floor surface.



Do not block, even partially, ventilation grid.
Avoid any possible re-circulation of the exhaust cooling air.
Protect the dryer from air drafts or forced cooling air conditions.

NOTE : Dryers models ACT 20 – 75 can be wall-mounted. See fixing dimensions on dimensional drawings in the attachment section.

The hanging mounting inevitably causes the obstruction of the ventilation grid positioned on the panel facing the wall fixing. This obstruction, in any case, does not prejudice the efficiency of the ventilation inside the dryer which is guaranteed by other grids on the other panels.

4.4 Installation layout

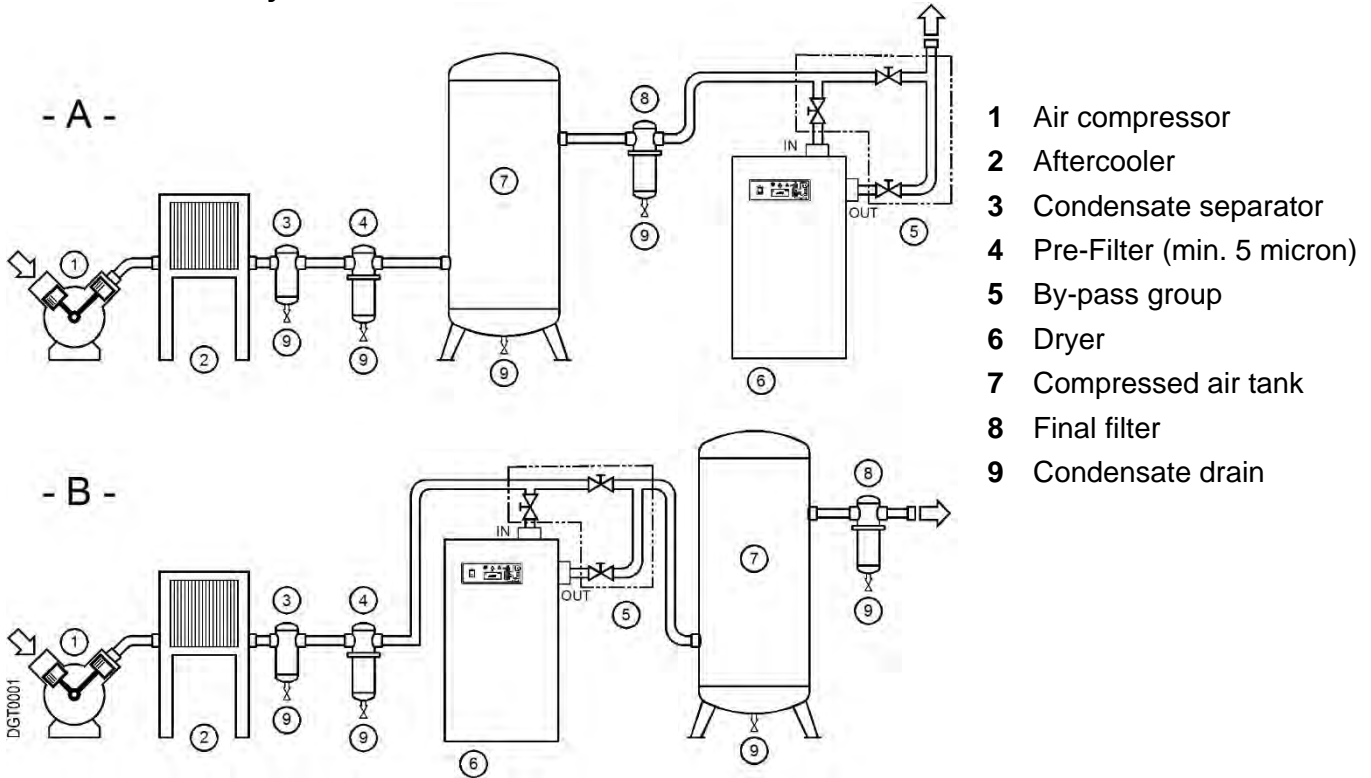

In case of heavily polluted inlet air (ISO 8573.1 class 3.-3 or worse quality), we recommend the additional installation of a pre-filter (5 micron minimum) to prevent a clogging of the heat exchanger.

Type A installation is suggested when the compressor operates at reduced intermittence and the total consumption equals the compressor flow rate.

Type B installation is suggested when the air consumption can consistently change with peak values highly exceeding the flow rate of the compressors. The capacity of the tank must be sized in order to compensate eventual instantaneous demanding conditions (peak air consumption).

Installation

4.5 Correction factors

Correction factor for operating pressure changes:

Inlet air pressure	psig	60	80	100	120	140	160	180	203
	barg	4	5.5	7	8	10	11	12	14
Factor (F1)		0.79	0.91	1.00	1.07	1.13	1.18	1.23	1.27

Correction factor for ambient temperature changes (Air-Cooled):

Ambient temperature	°F	≤ 80	90	95	100	105	110	115	122
	°C	≤ 27	32	35	38	40	43	45	50
Factor (F2)		1.11	1.09	1.06	1.00	0.94	0.87	0.78	0.69

Correction factor for inlet air temperature changes:

Air temperature	°F	≤ 90	100	110	122	130	140	150	158
	°C	≤ 32	38	43	50	55	60	65	70
Factor (F3)		1.16	1.00	0.82	0.68	0.61	0.52	0.45	0.40

Correction factor for DewPoint changes:

DewPoint	°F	38	41	45	50
	°C	3	5	7	10
Factor (F4)		1.00	1.08	1.20	1.36

How to find the air flow capacity:

Air flow capacity = Nominal duty x Factor (F1) x Factor (F2) x Factor (F3) x Factor (F4)

Example:

An **ACT 75** has a nominal duty of 75 scfm (127 m³/h). What is the maximum allowable flow through the dryer under the following operating conditions:

Inlet air pressure = 120 psig (8 barg)	Factor (F1) = 1.07
Ambient temperature = 115°F (45°C)	Factor (F2) = 0.78
Inlet air temperature = 122°F (50°C)	Factor (F3) = 0.68
Pressure DewPoint = 50°F (10°C)	Factor (F4) = 1.36

Each item of data has a corresponding numerical factor which multiplied by the design air flow is as follows:

Air flow capacity = 75 x 1.07 x 0.78 x 0.68 x 1.36 = 58 scfm (99 m³/h)

58 scfm (99 m³/h) This is the maximum flow rate that the dryer can accept under these operating conditions.

How to select a suitable dryer for a given duty:

Minimum std. air flow rate = $\frac{\text{Design air flow}}{\text{Factor (F1) x Factor (F2) x Factor (F3) x Factor (F4)}}$

Example:

With the following operating parameters:

Design air flow = 100 scfm (170 m ³ /h)	Factor (F1) = 1.07
Inlet air pressure = 120 psig (8 barg)	Factor (F2) = 0.78
Ambient temperature = 115°F (45°C)	Factor (F3) = 0.68
Inlet air temperature = 122°F (50°C)	Factor (F4) = 1.36
Pressure DewPoint = 50°F (10°C)	

In order to select the correct dryer model the required flow rate is to be divided by the correction factors relating to above mentioned parameters:

Minimum std. air flow rate = $\frac{100}{1.07 \times 0.78 \times 0.68 \times 1.36} = 130 \text{ scfm (221 m}^3\text{/h)}$

Therefore the model suitable for the conditions above is **ACT 150 (150 scfm [255 m³/h] - nominal duty).**

4.6 Connection to the compressed air system



Operations to be performed by qualified personnel only.

Never work on system under pressure.

The user is responsible to ensure that the dryer will never be operated with pressure exceeding the maximum pressure rating on the unit data tag.

Over-pressurizing the dryer could be dangerous for both the operator and the unit.

The air temperature and the flow entering the dryer must comply within the limits stated on the data nameplate. The system connecting piping must be kept free from dust, rust, chips and other impurities, and must be consistent with the flow-rate of the dryer. In case of treatment of air at particularly high temperature, the installation of a final refrigerator could result necessary. In order to perform maintenance operations, it is recommended to install a dryer by-pass system.



In case of heavily polluted inlet air (ISO 8573.1 class 3.-3 or worse quality), we recommend the additional installation of a pre-filter (5 micron minimum) to prevent a clogging of the heat exchanger.

In realising the dryer, particular measures have been taken in order to limit the vibration which could occur during the operation. Therefore we recommend to use connecting pipes able to insulate the dryer from possible vibrations originating from the line (flexible hoses, vibration damping fittings, etc.).



CAUTION :

PIPING THE DRYER, INLET/OUTLET CONNECTIONS MUST BE SUPPORTED AS SHOWN IN THE DIAGRAM.

FAILING WILL RESULT IN DAMAGE.

4.7 Connection to the cooling water network (Water-Cooled)



Operations to be performed by qualified personnel only.

Never work on system under pressure.

The user is responsible to ensure that the dryer will never be operated with pressure exceeding the maximum pressure rating on the unit data tag.

Over-pressurizing the dryer could be dangerous for both the operator and the unit.

The temperature and the amount of cooling water must comply with the limits indicated on the technical characteristics chart. The cross section of the connection pipes, preferably flexible, must be free from rust, chips and other impurities. We recommend to use connecting pipes able to insulate the dryer from possible vibrations originating from the line (flexible hoses, vibration damping fittings, etc.).



We recommend the installation of a 500 micron filter to prevent a clogging of the heat exchanger.

Minimum cooling water requirements:

Temperature	59...86°F (15...30°C) (1)	HCO ₃ / SO ₄	>1.0 mg/l or ppm
Pressure	44...145 psig (3...10 barg) (2)	NH ₃	<2 mg/l or ppm
Head pressure	> 44 psig (3 bar) (2) (3)	Cl ⁻	50 mg/l or ppm
Total hardness	6.0...15	Cl ₂	0.5 mg/l or ppm
PH	7.5...9.0	H ₂ S	<0.05 mg/l or ppm
Conductivity	10...500 μS/cm	CO ₂	<5 mg/l or ppm
Residual solid particles	<30 mg/l or ppm	NO ₃	<100 mg/l or ppm
Saturation Index SI	-0.2 < 0 < 0.2	Fe	<0.2 mg/l or ppm
HCO ₃	70...300 mg/l or ppm	Al	<0.2 mg/l or ppm
SO ₄ ²⁻	<70 mg/l or ppm	Mn	<0.1 mg/l or ppm

Note : (1) – Other temperature on request - Check the data shown on the identification plate.

(2) – Other pressure on request - Check the data shown on the identification plate.

(3) – Pressure difference at dryer water connection points at maximum water flow - Other head pressure on request



CAUTION :

PIPING THE DRYER, INLET/OUTLET CONNECTIONS MUST BE SUPPORTED AS SHOWN IN THE DIAGRAM.

FAILING WILL RESULT IN DAMAGE.

4.8 Electrical connections



Qualified personnel should carry out connecting unit to the main power.
Be sure to check the local codes in your area.

Before connecting the unit to the electrical supply, verify the data nameplate for the proper electrical information. Voltage tolerance is +/- 10%.

Dryer are supplied with power cord and plug (two poles and ground) or with a junction box.

Be sure to provide the proper fuses or breakers based on the data information located on the nameplate.

The mains socket must be provided with a mains magneto-thermal differential breaker ($I_{\Delta n} = 0.03A$), adjusted on the basis of the consumption of the dryer (see the nominal values on the data plate of the dryer). The cross section of the power supply cables must comply with the consumption of the dryer, while keeping into account also the ambient temperature, the conditions of the mains installation, the length of the cables, and the requirements enforced by the local Power Provider.



Important: ensure that the dryer is earthed.

Do not use any socket adapters at the mains plug.

If the mains plug needs to be replaced, this must only be done by a qualified electrician.

4.9 Condensate drain



The condensate is discharge at the system pressure.
Drain line should be secured.



Never point the condensate drain line towards anybody.

The dryer comes already fitted with a timed condensate drainer (solenoid valve controlled by electronic instrument) or with an electronic condensate drainer (optional).

Connect and properly fasten the condensate drain to a collecting plant or container.

The drain cannot be connected to pressurized systems.



Don't dispose the condensate in the environment.

The condensate collected in the dryer contains oil particles released in the air by the compressor.

Dispose the condensate in compliance with the local rules.

We recommend to install a water-oil separator where to convey all the condensate drain coming from compressors, dryers, tanks, filters, etc.

5 Start-up

5.1 Preliminary operation



Verify that the operating parameters match with the nominal values stated on the data nameplate of the dryer (voltage, frequency, air pressure, air temperature, ambient temperature, etc.).

This dryer has been thoroughly tested, packaged and inspected prior to shipment. Nevertheless, the unit could be damaged during transportation, check the integrity of the dryer during first start-up and monitor operation during the first hours of operation.



Qualified personnel must perform the first start-up.

When installing and operating this equipment, comply with all National Electrical Code and any applicable federal, state and local codes.



Who is operating the unit is responsible for the proper and safe operation of the dryer.
Never operate equipment with panels removed.

5.2 First start-up



This procedure should be followed on first start-up, after periods of extended shutdown or following maintenance procedures. Qualified personnel must perform the start-up.



Sequence of operations (refer to paragraph 7.1 Control Panel).

- Ensure that all the steps of the “Installation” chapter have been observed.
- Ensure that the connection to the compressed air system is correct and that the piping is suitably fixed and supported.
- Ensure that the condensate drain pipe is properly fastened and connected to a collection system or container.
- Ensure that the by-pass system (if installed) is closed and the dryer is isolated.
- Ensure that the manual valve of the condensate drain circuit is open.
- Remove any packaging and other material which could obstruct the area around the dryer.
- Activate the mains switch.
- **ACT 200-500 3phase** - Turn on the main switch - pos. A on the control panel.
- **ACT 200-500 3phase** - Wait at least two hours before starting the dryer (compressor crankcase heater must heat the oil of the compressor).
- Ensure the cooling water flow and temperature is adequate (Water-Cooled).
- Turn ON the switch - pos. 1 on the control panel.
- Ensure that electronic instrument is ON.
- Ensure the consumption matches with the values of the data plate.
- **ACT 200-500 3phase** - Check the rotation direction of the fan – wait for its first interventions (Air-Cooled).
- Allow the dryer temperature to stabilise at the pre-set value.
- Slowly open the air inlet valve.
- Slowly open the air outlet valve.
- Slowly close the central by-pass valve of the system (if installed).
- Check the piping for air leakage.
- Ensure the drain is regularly cycling - wait for its first interventions.

5.3 Start-up and shut down



ACT 200-500 3phase - For short periods of inactivity, (max 2-3 days) we recommend that power is maintained to the dryer and the control panel. Otherwise, before re-starting the dryer, it is necessary to wait at least 2 hours for the compressor crankcase heater to heat the oil of the compressor.



Start-up (refer to paragraph 7.1 Control Panel)

- Check the condenser for cleanliness (Air-Cooled).
- Ensure the cooling water flow and temperature is adequate (Water-Cooled).
- Turn ON the switch - pos. 1 on the control panel.
- Ensure that electronic instrument is ON.
- Wait a few minutes; verify that the DewPoint temperature displayed on electronic instrument is correct and that the condensate is regularly drained.
- Switch on the air compressor.



Shut down (refer to paragraph 7.1 Control Panel)

- Check that the DewPoint temperature indicated on the electronic instrument is within range.
- Shut down the air compressor.
- After a few minutes, turn OFF the switch - pos. 1 on the control panel.



ACT 200-500 3phase - Dryer remote control ON-OFF

- Remove jump on terminals 1 and 2 of the terminal strip and wire a dry contact – potential free (see electric diagram).
- Turn ON the switch - pos. 1 on the control panel.
- Close contact on terminal 1 and 2 switch ON the dryer
- Open contact on terminal 1 and 2 switch OFF the dryer



Use dry contacts only (potential free) suitable for low voltage. Assure an adequate isolation of potentially dangerous powered parts.



CAUTION :

AUTO-RESTART / REMOTE ON-OFF.

THE DRYER MAY POWER UP WITHOUT BEING ACTED UPON.

THE USER WILL BE RESPONSIBLE FOR THE INSTALLATION OF PROPER PROTECTIONS FOR POSSIBLE SUDDEN POWER RESTORATION TO THE DRYER.

NOTE : A DewPoint within 32°F (0°C) and +50°F (+10°C) displayed on electronic instrument is correct according to the possible working conditions (flow-rate, temperature of the incoming air, ambient temperature, etc.).

During the operation, the refrigerant compressor will run continuously. The dryer must remain on during the full usage period of the compressed air, even if the air compressor works intermittently.



The number of starts must be no more than 6 per hour.

The dryer must stop running for at least 5 minutes before being started up again.

Frequent starts may cause irreparable damage.

The user is responsible for compliance with these rules.

6 Technical data

6.1 Technical data ACT 20 – 200 1/115/60

MODEL	ACT	20-UP	30-UP	50-UP	75-UP	100-UP	125-UP	150-UP	200-UP
Air flow rate at nominal condition (1)	[scfm] [m ³ /h] [l/min]	20 34 566	30 51 849	50 85 1415	75 127 2123	100 170 2830	125 212 3538	150 255 4245	200 340 5660
Pressure DewPoint at nominal condition (1)	[°F (°C)]	38 (3)							
Nominal ambient temperature	[°F (°C)]	100 (38)							
Min...Max ambient temperature	[°F (°C)]	34...122 (1...50)							
Nominal inlet air temperature	[°F (°C)]	100 (38) max.158 (70)							
Nominal inlet air pressure	[psig (barg)]	100 (7)							
Max. inlet air pressure	[psig (barg)]	230 (16)							
Air pressure drop - Δp	[psi (bar)]	0.4 (0.03)	1.0 (0.07)	2.2 (0.15)	2.2 (0.15)	2.0 (0.14)	2.6 (0.18)	3.3 (0.23)	1.7 (0.12)
Inlet - Outlet connections	[NPT-F]	1/2" 1.1/4"							

		R134.a					R407C			
Refrigerant type		R134.a					R407C			
Refrigerant quantity (2)	[oz (kg)]	6.3 (0.18)	8.1 (0.23)	9.9 (0.28)	12 (0.35)	13 (0.38)	20 (0.58)	21 (0.60)	32 (0.90)	
Cooling air fan flow	[cfm (m ³ /h)]	180 (300)					350 (600)			
Heat Rejection	[btu/hr (kW)]	1800 (0.53)	2290 (0.67)	4090 (1.20)	4810 (1.44)	6790 (1.99)	12900 (3.78)	13100 (3.84)	13500 (3.96)	
Standard Power Supply (2)	[Ph/V/Hz]	1/115/60								
Nominal electric consumption	[kW]	0.26	0.27	0.39	0.48	0.58	1.00	1.05	1.10	
Full Load Amperage FLA	[A]	2.4	2.5	3.5	4.4	5.2	9.0	9.7	10.1	
Max. noise level at 1 m	[dba]	4.5 7.1 8.7 12.5								
Weight	[lb (kg)]	64 (29)	68 (31)	75 (34)	79 (36)	82 (37)	101 (46)	110 (50)	121 (55)	

Refrigerant type		R407C
Refrigerant quantity (2)	[oz (kg)]	28 (0.80)
Max. cooling water inlet temp (3)	[°F (°C)]	86 (30)
Min...Max. cooling water inlet pressure	[psig (barg)]	45...145 (3...10)
Cooling water flow at 15°C	[US gpm (m ³ /h)]	0.53 (0.12)
Cooling water flow at 30°C	[US gpm (m ³ /h)]	1.94 (0.44)
Heat Rejection	[btu/hr (kW)]	13500 (3.96)
Control of cooling water flow		Automatic by valve
Cooling water connection	[NPT-F]	1/2"
Standard Power Supply (2)	[Ph/V/Hz]	1/115/60
Nominal electric consumption	[kW]	1.00
Full Load Amperage FLA	[A]	9.2
Max. noise level at 1 m	[dba]	12.8
Weight	[lb (kg)]	< 70 117 (53)

(1) The nominal condition refers to an ambient temperature of 100°F (38°C) with inlet air at 100 psig (7 barg) and 100°F (38°C).

(2) Check the data shown on the identification plate.

(3) Other temperature on request.

6.2 Technical data ACT 20 – 500 1/230/60

MODEL	ACT	20-UE	30-UE	50-UE	75-UE	100-UE	125-UE	150-UE	200-UE	250-UE	300-UE	350-UE	400-UE	500-UE	
Air flow rate at nominal condition (1)	[scfm] [m ³ /h]	20 34	30 51	50 85	75 127	100 170	125 212	150 255	200 340	250 425	300 509	350 594	400 679	500 849	
Pressure DewPoint at nominal condition (1)	[°F (°C)]	566	849	1415	2123	2830	3538	4245	5660	7075	8490	9905	11320	14150	
Nominal ambient temperature	[°F (°C)]	38 (3)													
Min...Max ambient temperature	[°F (°C)]	100 (38)													
Nominal inlet air temperature	[°F (°C)]	34...122 (1...50)													
Nominal inlet air pressure	[psig (bar)]	100 (38) max.158 (70)													
Max. inlet air pressure	[psig (bar)]	100 (7)													
Air pressure drop - Δp	[psi (bar)]	230 (16)													
Inlet - Outlet connections	[NPT-F]	1/2"	1"	2.2 (0.15)	2.2 (0.15)	2.0 (0.14)	2.6 (0.18)	3.3 (0.23)	1.7 (0.12)	3.6 (0.25)	1.5 (0.10)	1.9 (0.13)	1.0 (0.07)	1.5 (0.10)	
						1.14"			1.1/2"		2"			2 1/2"	

		R134.a													
		1/230/60													
Refrigerant type		R407C													
Refrigerant quantity (2)	[oz (kg)]	6.3 (0.18)	8.1 (0.23)	9.9 (0.28)	12 (0.35)	13 (0.38)	20 (0.58)	21 (0.60)	32 (0.90)	37 (1.05)	55 (1.55)	56 (1.60)	92 (2.60)		
Cooling air fan flow	[cfm (m ³ /h)]	180 (300)	240 (400)	350 (600)	530 (900)	1500 (2500)	1550 (2600)	2100 (3500)	2700 (4500)	3500 (6000)	5300 (9000)	5500 (9500)	9200 (15500)	15000 (25000)	
Heat Rejection	[btu/hr (kW)]	1800 (0.53)	2490 (0.73)	3200 (0.94)	4100 (1.20)	6690 (1.96)	12800 (3.75)	13000 (3.81)	13200 (3.87)	17200 (5.04)	20300 (5.95)	26600 (7.80)	27300 (8.00)	27500 (8.06)	
Standard Power Supply (2)	[PhV/Hz]	0.19	0.26	0.39	0.48	0.58	1.00	1.05	1.10	1.39	1.64	2.19	2.48	2.50	
Nominal electric consumption	[kW]	1.1	1.3	2.1	2.7	3.4	4.5	4.8	5.1	6.4	7.6	10.0	11.3	11.4	
Full Load Amperage A	[A]	1.6	2.3	2.7	3.6	4.9	7.3	7.4	8.3	10.3	14.0	15.0	15.0	15.0	
Max. noise level at 1 m	[dba]	< 70													
Weight	[lb (kg)]	62 (28)	64 (29)	75 (34)	79 (36)	82 (37)	101 (46)	110 (50)	121 (55)	139 (63)	203 (92)	207 (94)	331 (150)	355 (161)	

		R407C													
Refrigerant type		Automatic by valve													
Refrigerant quantity (2)	[oz (kg)]	28 (0.80)	33 (0.95)	49 (1.40)	51 (1.45)	85 (2.40)									
Max. cooling water inlet temp (3)	[°F (°C)]	86 (30)													
Min...Max. cooling water inlet pressure	[psig (bar)]	45...145 (3...10)													
Cooling water flow at 15°C	[US gpm (m ³ /h)]	0.53 (0.12)	0.66 (0.15)	0.70 (0.16)	0.84 (0.19)	0.92 (0.21)	1.01 (0.23)								
Cooling water flow at 30°C	[US gpm (m ³ /h)]	1.94 (0.44)	2.55 (0.58)	2.69 (0.61)	2.99 (0.68)	3.13 (0.71)	3.35 (0.76)								
Heat Rejection	[btu/hr (kW)]	13200 (3.87)	17200 (5.04)	20300 (5.95)	26600 (7.80)	27300 (8.00)	27500 (8.06)								
Control of cooling water flow		1/2"													
Cooling water connection	[NPT-F]	1/230/60													
Standard Power Supply (2)	[PhV/Hz]	1/230/60													
Nominal electric consumption	[kW]	1.00	1.30	1.42	1.77	2.01	2.07								
Full Load Amperage FLA	[A]	4.7	6.0	6.7	8.6	9.2	9.6								
Max. noise level at 1 m	[dba]	7.1	8.0	9.6	13.3	14.3									
Weight	[lb (kg)]	117 (53)	134 (61)	196 (89)	201 (91)	324 (147)	348 (158)								

(1) The nominal condition refers to an ambient temperature of 100°F (38°C) with inlet air at 100 psig (7 barg) and 100°F (38°C).
 (2) Check the data shown on the identification plate.
 (3) Other temperature on request.

Technical data

6.3 Technical data ACT 200 – 500 3phase 3/460/60

MODEL	ACT	200-UR	250-UR	300-UR	350-UR	400-UR	500-UR
Air flow rate at nominal condition (1)	[scfm]	200	250	300	350	400	500
	[m ³ /h]	340	425	509	594	679	849
	[l/min]	5660	7075	8490	9905	11320	14150
Pressure DewPoint at nominal condition (1)	[°F (°C)]	38 (3)					
Nominal ambient temperature	[°F (°C)]	100 (38)					
Min...Max ambient temperature	[°F (°C)]	34...122 (1...50)					
Nominal inlet air temperature	[°F (°C)]	100 (38) max.158 (70)					
Nominal inlet air pressure	[psig (barg)]	100 (7)					
Max. inlet air pressure	[psig (barg)]	203 (14)					
Air pressure drop - Δp	[psi (bar)]	1.7 (0.12)	3.6 (0.25)	1.5 (0.10)	1.9 (0.13)	1.0 (0.07)	1.5 (0.10)
Inlet - Outlet connections	[NPT-F]	1.1/2"		2"		2.1/2"	

Air-Cooled	Refrigerant type	R134.a				R407C		
	Refrigerant quantity (2)	[oz (kg)]	37 (1.05)	41 (1.15)	60 (1.70)	63 (1.80)	74 (2.10)	81 (2.30)
	Cooling air fan flow	[cfm (m ³ /h)]	1500 (2500)	1650 (2800)		1700 (2900)	2100 (3600)	2200 (3700)
	Heat Rejection	[btu/hr (kW)]	13700 (4.02)	14200 (4.16)	14900 (4.37)	18200 (5.33)	24900 (7.30)	32300 (9.47)
	Standard Power Supply (2)	[Ph/V/Hz]	3/460/60					
	Nominal electric consumption	[kW]	1.22	1.38	1.41	1.80	2.70	2.97
		[A]	1.9	2.1	2.2	2.8	4.2	4.5
	Full Load Amperage FLA	[A]	2.8			4.5	6.4	7.4
	Max. noise level at 1 m	[dbA]	< 70					
	Weight	[lb (kg)]	159 (72)	176 (80)	238 (108)	243 (110)	353 (160)	375 (170)

Water-Cooled	Refrigerant type	R134.a				R407C		
	Refrigerant quantity (2)	[oz (kg)]	33 (0.95)	37 (1.05)	55 (1.55)	56 (1.60)	67 (1.90)	74 (2.10)
	Max. cooling water inlet temp (3)	[°F (°C)]	86 (30)					
	Min...Max. cooling water inlet pressure	[psig (barg)]	45...145 (3...10)					
	Cooling water flow at 15°C	[US gpm (m ³ /h)]	0.48 (0.11)	0.57 (0.13)	0.62 (0.14)	0.70 (0.16)	0.84 (0.19)	0.97 (0.22)
	Cooling water flow at 30°C	[US gpm (m ³ /h)]	1.89 (0.43)	2.03 (0.46)	2.33 (0.53)	2.55 (0.58)	3.17 (0.72)	3.48 (0.79)
	Heat Rejection	[btu/hr (kW)]	13700 (4.02)	14200 (4.16)	14900 (4.37)	18200 (5.33)	24900 (7.30)	32300 (9.47)
	Control of cooling water flow		Automatic by valve					
	Cooling water connection	[NPT-F]	1/2"				3/4"	
	Standard Power Supply (2)	[Ph/V/Hz]	3/460/60					
Nominal electric consumption	[kW]	1.03	1.19	1.24	1.62	2.16	2.38	
	[A]	1.8		1.9	2.4	2.8	3.7	
Full Load Amperage FLA	[A]	2.2			3.9	5.1	6.1	
Max. noise level at 1 m	[dbA]	< 70						
Weight	[lb (kg)]	152 (69)	170 (77)	231 (105)	236 (107)	353 (160)	368 (167)	

(1) The nominal condition refers to an ambient temperature of 100°F (38°C) with inlet air at 100 psig (7 barg) and 100°F (38°C).

(2) Check the data shown on the identification plate.

(3) Other temperature on request.

Technical data

6.4 Technical data ACT 200 – 500 3phase 3/575/60

MODEL	ACT	200-UQ	250-UQ	300-UQ	350-UQ	400-UQ	500-UQ
Air flow rate at nominal condition (1)	[scfm]	200	250	300	350	400	500
	[m ³ /h]	340	425	509	594	679	849
	[l/min]	5660	7075	8490	9905	11320	14150
Pressure DewPoint at nominal condition (1)	[°F (°C)]	38 (3)					
Nominal ambient temperature	[°F (°C)]	100 (38)					
Min...Max ambient temperature	[°F (°C)]	34...122 (1...50)					
Nominal inlet air temperature	[°F (°C)]	100 (38) max.158 (70)					
Nominal inlet air pressure	[psig (barg)]	100 (7)					
Max. inlet air pressure	[psig (barg)]	203 (14)					
Air pressure drop - Δp	[psi (bar)]	1.7 (0.12)	3.6 (0.25)	1.5 (0.10)	1.9 (0.13)	1.0 (0.07)	1.5 (0.10)
Inlet - Outlet connections	[NPT-F]	1.1/2"		2"		2.1/2"	

Air-Cooled	Refrigerant type	R134.a				R407C		
	Refrigerant quantity (2)	[oz (kg)]	37 (1.05)	41 (1.15)	60 (1.70)	63 (1.80)	74 (2.10)	81 (2.30)
	Cooling air fan flow	[cfm (m ³ /h)]	1500 (2500)	1650 (2800)		1700 (2900)	2100 (3600)	2200 (3700)
	Heat Rejection	[btu/hr (kW)]	13700 (4.02)	14200 (4.16)	14900 (4.37)	18200 (5.33)	24900 (7.30)	32300 (9.47)
	Standard Power Supply (2)	[Ph/V/Hz]	3/575/60					
	Nominal electric consumption	[kW]	1.22	1.38	1.41	1.80	2.70	2.97
		[A]	1.5	1.7	1.8	2.2	3.4	3.6
	Full Load Amperage FLA	[A]	2.2			3.6	5.1	5.9
	Max. noise level at 1 m	[dbA]	< 70					
	Weight	[lb (kg)]	159 (72)	176 (80)	238 (108)	243 (110)	353 (160)	375 (170)

Water-Cooled	Refrigerant type	R134.a				R407C		
	Refrigerant quantity (2)	[oz (kg)]	33 (0.95)	37 (1.05)	55 (1.55)	56 (1.60)	67 (1.90)	74 (2.10)
	Max. cooling water inlet temp (3)	[°F (°C)]	86 (30)					
	Min...Max. cooling water inlet pressure	[psig (barg)]	45...145 (3...10)					
	Cooling water flow at 15°C	[US gpm (m ³ /h)]	0.48 (0.11)	0.57 (0.13)	0.62 (0.14)	0.70 (0.16)	0.84 (0.19)	0.97 (0.22)
	Cooling water flow at 30°C	[US gpm (m ³ /h)]	1.89 (0.43)	2.03 (0.46)	2.33 (0.53)	2.55 (0.58)	3.17 (0.72)	3.48 (0.79)
	Heat Rejection	[btu/hr (kW)]	13700 (4.02)	14200 (4.16)	14900 (4.37)	18200 (5.33)	24900 (7.30)	32300 (9.47)
	Control of cooling water flow		Automatic by valve					
	Cooling water connection	[NPT-F]	1/2"				3/4"	
	Standard Power Supply (2)	[Ph/V/Hz]	3/575/60					
Nominal electric consumption	[kW]	1.25	1.44	1.50	1.96	2.61	2.88	
	[A]	1.4		1.5	1.9	2.2	3.0	
Full Load Amperage FLA	[A]	1.8			3.1	4.1	4.9	
Max. noise level at 1 m	[dbA]	< 70						
Weight	[lb (kg)]	152 (69)	170 (77)	231 (105)	236 (107)	353 (160)	368 (167)	

(1) The nominal condition refers to an ambient temperature of 100°F (38°C) with inlet air at 100 psig (7 barg) and 100°F (38°C).

(2) Check the data shown on the identification plate.

(3) Other temperature on request.

7 Technical description

7.1 Control panel

The control panel illustrated below is the only dryer-operator interface.

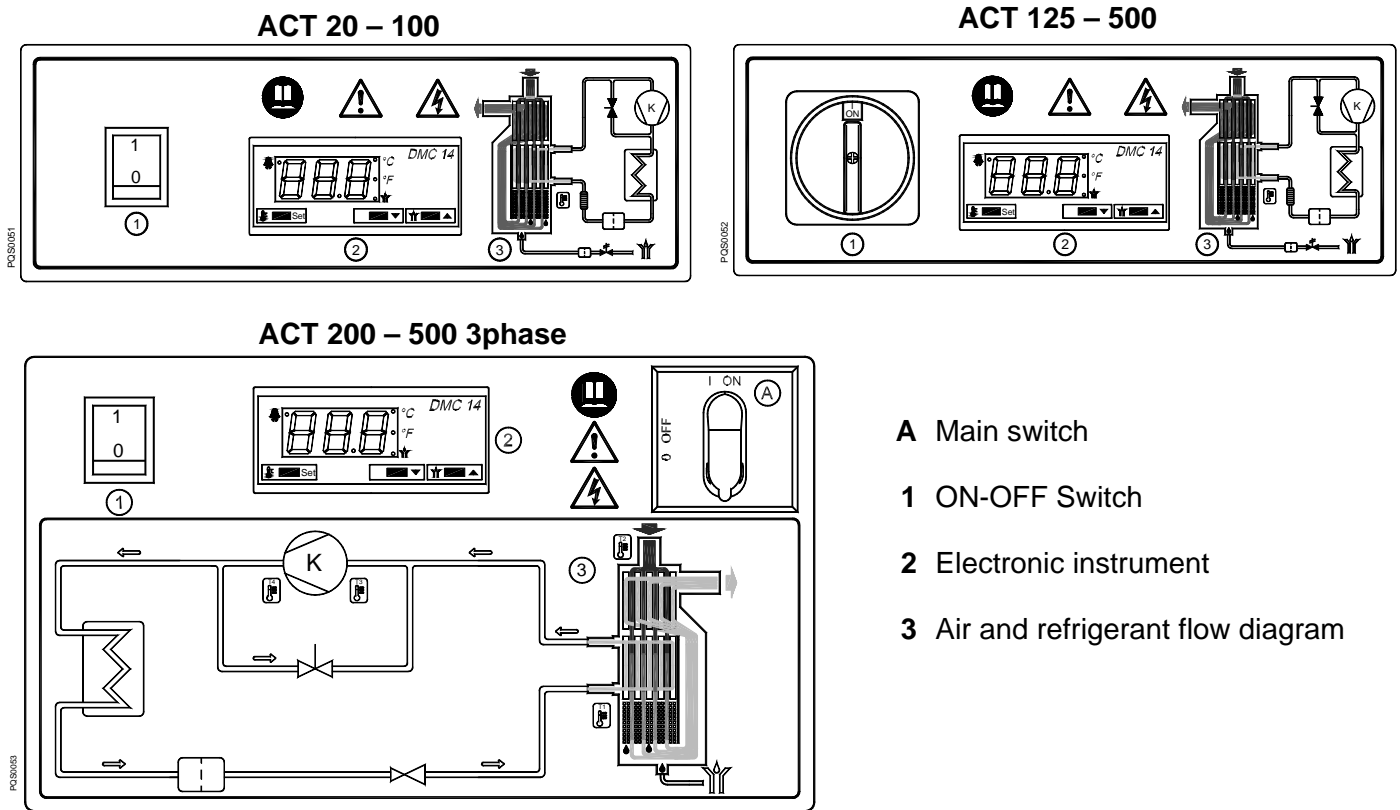

7.2 Operation

Operating principle - The dryer models described in this manual operate all on the same principle. The hot moisture laden air enters an air to air heat exchanger. The air then goes through the evaporator, also known as the air to refrigerant heat exchanger. The temperature of the air is reduced to approximately 36°F (2°C), causing water vapor to condense to liquid. The liquid is continuously coalesced and collected in the separator for removal by the condensate drain. The cool moisture free air then passes back through the air to air heat exchanger to be reheated to within 8 degrees of the incoming air temperature as it exits the dryer.

Refrigerant circuit - Refrigerant gas is cycled through the compressor and exits at high pressure to a condenser where heat is removed causing the refrigerant to condense to a high-pressure liquid state. The liquid is forced through a capillary tube where the resulting pressure drop allows the refrigerant to boil off at a predetermined temperature. Low-pressure liquid refrigerant enters the heat exchanger where heat from the incoming air is transferred causing the refrigerant to boil; the resulting phase change produces a low pressure, low temperature gas. The low-pressure gas is returned to the compressor, where it is re-compressed and begins the cycle again. During those periods when the compressed air load is reduced the excess refrigerant is by-passed automatically back to the compressor via the hot gas by-pass valve circuit.

7.3 Flow diagram (Air-Cooled)

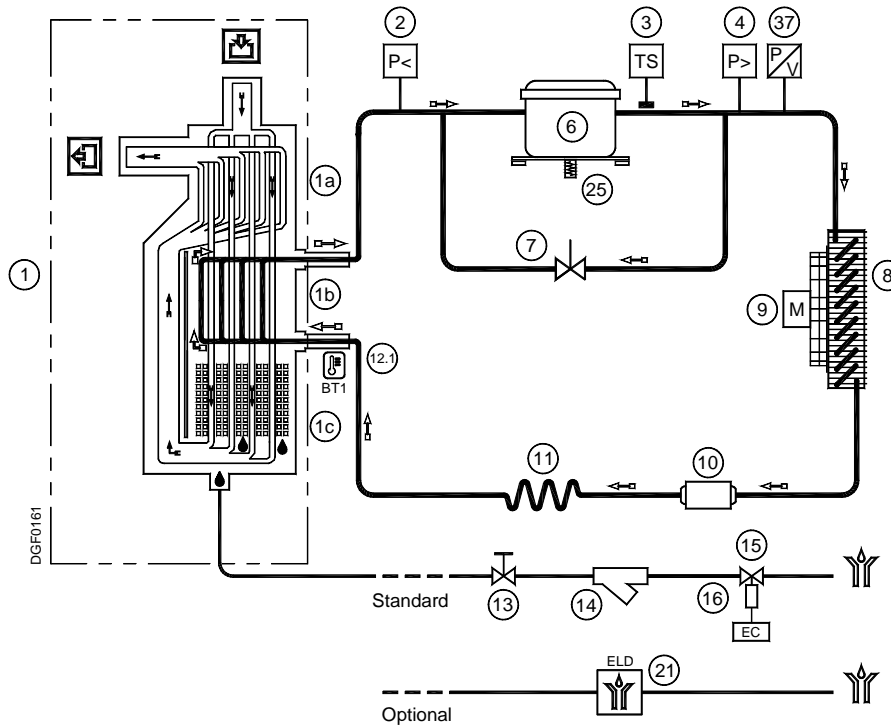

7.4 Flow diagram (Water-Cooled)

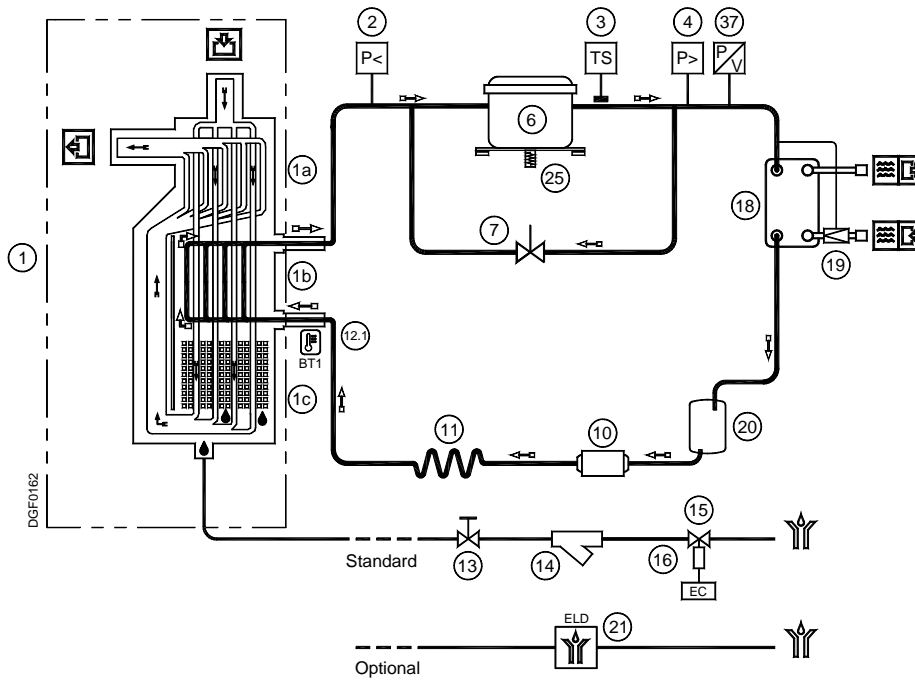

- | | |
|--|--|
| <ul style="list-style-type: none"> 1 Alu-Dry module 1a Air-to-air heat exchanger 1b Air-to-refrigerant heat exchanger 1c Condensate separator 2 Refrigerant pressure switch LPS (ACT 300-500 & ACT 200-500 3phase) 3 Safety thermo switch TS (ACT 125-500 & ACT 200-500 3phase) 4 Refrigerant pressure switch HPS (ACT 300-500 & ACT 200-500 3phase) 6 Compressor 7 Hot gas by-pass valve 8 Condenser (Air-Cooled) 9 Condenser fan (Air-Cooled) | <ul style="list-style-type: none"> 10 Filter dryer 11 Capillary tube 12 Temperature probe T1 – DewPoint 13 Condensate drain service valve 14 Condensate drain strainer 15 Condensate drain solenoid valve 16 Coil for condensate drain solenoid valve 17 Electronic instrument 18 Condenser (Water-Cooled) 19 Condenser water regulating valve (Water-Cooled) 20 Refrigerant accumulator (Water-Cooled) 21 Electronic drainer 25 Compressor crankcase heater (ACT 200-500 3ph.) 37 Pressure transducer BP2 |
|--|--|
- Compressed air flow direction
 Refrigerant gas flow direction

7.5 Refrigerating compressor

The refrigerating compressor is the pump in the system, gas coming from the evaporator (low pressure side) is compressed up to the condensation pressure (high pressure side). The compressors utilized are manufactured by leading manufacturers and are designed for applications where high compression ratios and wide temperature changes are present.

The hermetically sealed construction is perfectly gas tight, ensuring high-energy efficiency and long, useful life. Dumping springs support the pumping unit in order to reduce the acoustic emission and the vibration diffusion. The aspirated refrigerant gas, flowing through the coils before reaching the compression cylinders cools the electric motor. The thermal protection protects the compressor from over heating and over currents. The protection is automatically restored as soon as the nominal temperature conditions are reached.

7.6 Condenser (Air-Cooled)

The condenser is the component in which the gas coming from the compressor is cooled down and condensed becoming a liquid. Mechanically, a serpentine copper tubing circuit (with the gas flowing inside) is encapsulated in an aluminum fin package.

The cooling operation occurs via a high efficiency fan, creating airflow within the dryer, moving air through the fin package. It's mandatory that the ambient air temperature does not exceed the nominal values. It is also important to keep the condenser unit free from dust and other impurities.

7.7 Condenser (Water-Cooled)

The condenser is the component in which the gas coming from the compressor is cooled down and condensed becoming a liquid. Basically it is a water/refrigerating gas exchanger where the cooling water lowers the temperature of the refrigerating gas.

The temperature of the inlet water must not exceed the nominal values. It must also guarantee an adequate flow and that the water entering the exchanger is free from dust and other impurities.

7.8 Condenser water regulating valve (Water-Cooled)

The condenser water regulating valve is used to keep the condensing pressure/temperature constant when the Water-Cooled is being used. Thanks to the capillary tube, the valve detects the pressure in the condenser and consequently adjusts the water flow. When the dryer stops the valve automatically closes the cooling water flow.



The condenser water regulating valve is an operating control device.

The closure of the water circuit from the pressure condenser water regulating valve cannot be used as a safety closure during service operations on the system.



ADJUSTMENT

The condenser water regulating valve is adjusted during the testing phase to a pre-set value that covers 90% of the applications. However, sometimes the extreme operating conditions of the dryer may require a more accurate calibration.

During start-up, a qualified technician should check the condensing pressure/temperature and if necessary adjust the valve by using the screws on the valve itself.

To increase the condensing temperature, turn the adjusting screws counter-clockwise; to lower it turn the screws clock-wise.

Water valve setting : R134.a pressure 145 psig (± 7.3 psi) [10 barg (± 0.5 bar)]

R407C pressure 232 psig (± 7.3 psi) [16 barg (± 0.5 bar)]

7.9 Filter dryer

Traces of humidity and slag can accumulate inside the refrigerant circuit. Long periods of use can also produce sludge. This can limit the lubrication efficiency of the compressor and clog the expansion valve or capillary tube. The function of the filter drier, located before the capillary tubing, is to eliminate any impurities from circulating through the system.

7.10 Capillary tube

It consists of a piece of reduced cross section copper tubing located between the condenser and the evaporator, acting as a metering device to reduce the pressure of the refrigerant. Reduction of pressure is a design function to achieve optimum temperature reached within the evaporator: the smaller the capillary tube outlet pressure, the lower the evaporation temperature.

The length and interior diameter of the capillary tubing is accurately sized to establish the performance of the dryer; no maintenance or adjustment is necessary.

7.15 Compressor crankcase heater

At low temperatures oil can more easily be mixed with the refrigerant gas. So, when the compressor starts, oil can be drawn into the refrigeration circuit and liquid hammering could occur.

To prevent this, an electrical resistance heater is installed in the suction side of the compressor. When the system is powered and the compressor is not running, this heater keeps the oil at the correct temperature. This heater is controlled by a thermo switch which prevents overheating the oil.

NOTE : The heater must be powered at least a couple of hours before the start up of the refrigeration compressor.

7.16 Electronic instrument DMC34

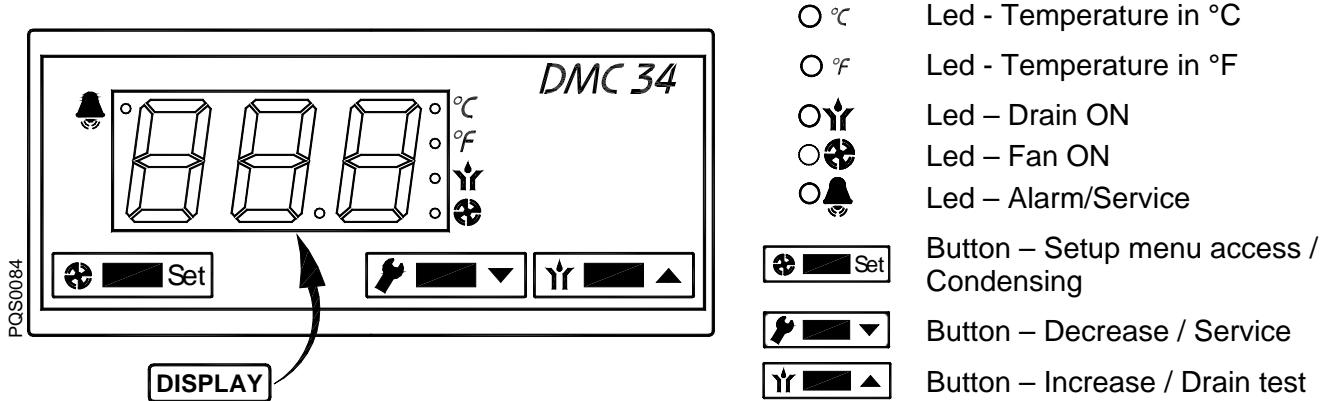

The DMC34 displays DewPoint temperature, controls the condenser fan activation, handles a service reminder and keep record of the total hours of operation of the dryer.

7.16.1 How to switch on the dryer

Power the dryer and switch it on using the ON-OFF switch (pos. 1 paragraph 7.1).

During normal operation the display shows the DewPoint temperature.

The condensate drain test is always active using the button .

7.16.2 How to switch off the dryer

Switch it off using the ON-OFF switch (pos. 1 paragraph 7.1).

7.16.3 How to display the operating parameters

During normal operation, the display shows the DewPoint temperature (in °C or °F).

Press and hold button to display condensing pressure.

Press and hold button to display hours until the next service.

Press and hold + buttons to display total hours of operation of the dryer (cannot be reset).

NOTE : with led ○ °C on temperatures are in °C and pressure in barg; with led ○ °F on temperatures are in °F and pressure in psig.

The total hours of operation and the hours until the next service are shown in the field 0...999 hours and in thousands of hours from 01.0 hours on (example : if the display shows number 35 it means 35 hours; if the display shows number 3.5 it means 3500 hours).





7.16.4 How a service warning / alarm is displayed

A service warning / alarm is an unusual event that must recall the attention of the operators/maintenance technicians. It does not stop the dryer.

When a service warning / alarm is active, the  led is flashing.

Service warnings / alarms are automatically reset as soon as the problem is solved and dryer is powered again. Scheduled Service reminder requires manual reset.

NOTE: the operator/maintenance technician must inspect the dryer and verify/solve the problem that generated the service warning.

Service Warning / Alarm	Description
 flashing + PF1 on display	PF1 - Probe 1 Failure : failure temperature probe BT1
 flashing + PF2 on display	PF2 - Probe 2 Failure : failure pressure probe BP2
 flashing + HdP on display	HdP - High DewPoint: DewPoint too high Set BT1>HdS, delay Hdd / Reset BT1<HdS-1°C (HdS-2°F)
 flashing + LdP on display	LdP - Low DewPoint : DewPoint too low Set BT1< -1°C (30°F), delay 5 minutes / Reset T1> 1°C (34°F)
 flashing + SrV on display	SrV - Service : maintenance service time expired SrV

7.16.5 How is controlled the condenser FAN

A pressure probe BP2 is located on the discharge side of the compressor. The condenser fan is activated (ON) when the BP2 pressure is higher than FANon setting (R134a approx. 11 barg/160 psig – R407C approx. 18 barg/260 psig) and led  is ON. Condenser fan stops when BP2 pressure is lower than FANoff setting (R134a approx. 8 barg/115 psig – R407C approx. 14 barg/203 psig).

7.16.6 How is controlled the drain solenoid valve



Drain solenoid valve is activated (ON) for **ton** seconds (standard 2 seconds) every **toF** minutes (standard 1 minute). Led  shows that condensate drain solenoid valve is ON.

The condensate drain test is always active using the button .

NOTE : if an electronic drainer is installed, DMC34 is set to keep always powered the drain output (**ton** =ON).

7.16.7 How to reset the service reminder timer

With dryer OFF keep pressed buttons  + , power the dryer and switch it on using the ON-OFF switch (pos.1 paragraph 7.1).

After 5 seconds display shows **SrV**, release buttons  + , keep pressed button  for 5 seconds. Timer has been reset and controller start to operate regularly.

Service reminder timing can be reset at any time, even before the timing has expired

7.16.8 Operation of the failure / alarm dry contact

The DMC34 is equipped with a dry contact (potential free) to display failure and/or alarm conditions.

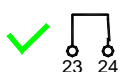

Dryer powered and no service warning / alarm is active.

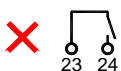

Dryer not powered or service warning / alarm is active.

7.16.9 How to change the operating parameters – SETUP menu

The setup menu can be used to change the dryer’s operating parameters.



Only qualified personnel must be allowed to access to the setup menu. The manufacturer is not responsible for malfunctioning or failure due to modification to the operating parameters.

With dryer ON simultaneously press buttons + for at least 5 seconds to enter the setup menu. Access to the menu is confirmed by message **ton** on the display (first parameter of menu).

Keep pressed to display the value of the selected parameter and use arrows and to change the value. Release the button to confirm the value and skip to following parameter.

Press + to exit setup menu (if no button is pressed after 2 minutes the menu is exited automatically).

ID	Description	Limits	Resolution	Standard setup
ton	Ton – drain time ON : time ON condensate drain valve ON = Electronic drainer installed	ON-00 ... 20 sec	1 sec	2
toF	ToF - drain time OFF : pause time for condensate drain valve	1 ... 20 min	1 min	1
HdS	HdS – High DewPoint Setting : Alarm threshold for a high DewPoint (the alarm disappears when the temperature drop 1°C / 2°F below alarm point)	0.0...25.0 °C or 32 ... 77 °F	0.5 °C or 1 °F	20 or 68
Hdd	Hdd - High DewPoint Delay : high DewPoint alarm enable delay	01 ... 20 minutes	1 min	15
SrV	SrV - Service Setting: setting of service warning timer. 00 = service warning timer disabled.	00.0 ... 20.0 (x 1000) hours	0.5 (x1000) hours	08.0
SrC	SrC – Service Contact : configuration of the alarm dry contact for the service warning timer. YES = activate the contact / NO = NOT activate the contact	YES / NO	-	YES
SCL	SCL - Scale: display scale of temperatures and pressure (°C = temperatures in °C and pressure in barg; °F = temperatures in °F and pressure in psig)	°C ... °F	-	°C

7.17 Electronic drainer (optional)

Instead of the usual drain system (a solenoid valve controlled by means of electronic instrument); an electronic level controlled drainer can be installed as option. This drainer consists of a condensate accumulator where a capacitive sensor continuously checking liquid level is placed: as soon as the accumulator is filled, the sensor passes a signal to the electronic control and a diaphragm solenoid valve will open to discharge the condensate. For a complete condensate discharge the valve opening time will be adjusted exactly for each single drain operation. No condensate strainers are installed. No adjusting is required. A service valve is installed before the electronic drain in order to make check and maintenance easily. **At dryer start-up verify that this valve is open.**

Control panel for dryers ACT 20 – 350 and ACT 200 – 350 3phase

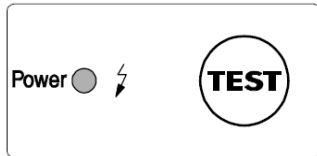

Power Led On - drainer ready to work / supplied
 TEST Button Discharge test (keep pushed for 2 seconds)

Control panel for dryers ACT 400 – 500 and ACT 400 – 500 3phase

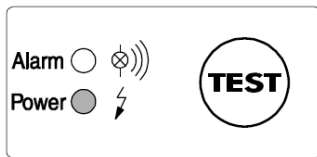

Power Led On - drainer ready to work / supplied
 Alarm Led Blinking - drainer in alarm condition
 TEST Button Discharge test (keep pushed for 2 seconds)

Troubleshooting



Only qualified personnel should perform troubleshooting and or maintenance operations.

Prior to performing any maintenance or service, be sure that :

- **no part of the machine is powered and that it cannot be connected to the mains supply.**
- **no part of the machine is under pressure and that it cannot be connected to the compressed air system.**
- **maintenance personnel have read and understand the safety and operation instructions in this manual.**

SYMPTOM	POSSIBLE CAUSE - SUGGESTED ACTION
◆ No led lighting up.	⇒ Verify that the system is powered. ⇒ Verify the electric wiring (internal and/or external). ⇒ Check internal printed circuit board for possible damage.
◆ Pressing of Test button, but no condensate discharge.	⇒ The service valve located before the drain is closed - open it. ⇒ The dryer is not under pressure - restore nominal condition. ⇒ Solenoid valve defective - replace the drain. ⇒ The internal printed circuit board is damaged - replace the drain.
◆ Condensate discharge only when Test button is pressed.	⇒ The capacitive sensor is too dirty - open the drain and clean the sensor plastic tube.
◆ Drain keeps blowing off air.	⇒ The diaphragm valve is dirty - open the drain and clean it. ⇒ The capacitive sensor is too dirty - open the drain and clean the sensor plastic tube.
◆ Drain in alarm condition.	⇒ The capacitive sensor is too dirty - open the drain and clean the sensor plastic tube. ⇒ The service valve located before the drain is closed - open it. ⇒ The dryer is not under pressure - restore nominal condition. ⇒ Solenoid valve defective - replace the drain.

NOTE : When the drain is in alarm condition, the diaphragm solenoid valve will open 7.5 sec every 4 min.

8 Maintenance, troubleshooting, spare parts and dismantling

8.1 Checks and maintenance



Only qualified personnel should perform troubleshooting and or maintenance operations.

Prior to performing any maintenance or service, be sure that :



- no part of the machine is powered and that it cannot be connected to the mains supply.
- no part of the machine is under pressure and that it cannot be connected to the compressed air system.
- maintenance personnel have read and understand the safety and operation instructions in this manual.



Before attempting any maintenance operation on the dryer, shut it down and wait at least 30 minutes. Some components can reach high temperature during operation. Avoid contact until system or component has dissipated heat.

Daily



- Verify that the DewPoint displayed on the electronic instrument is correct.
- Check the proper operation of the condensate drain systems.
- Verify the condenser for cleanliness (Air-Cooled).

Every 200 hours or monthly



- With an air jet (max. 2 bar / 30 psig) blowing from inside towards outside clean the condenser; repeat this operation blowing in the opposite way; be careful not to damage the aluminum fins of the cooling package (Air-Cooled)



- Close the manual condensate drain valve, unscrew the strainer (if installed) and clean it with compressed air and brush. Reinstall the strainer properly tight, and then open the manual valve.
- At the end, check the operation of the machine

Every 1000 hours or yearly



- Verify for tightness all the screws of the electric system and that all the “Disconnects-Tabs” type connections are in their proper position inspect unit for broken, cracked or bare wires.
- Inspect refrigerating circuit for signs of oil and refrigerant leakage.
- Measure and record amperage. Verify that readings are within acceptable parameters as listed in specification table.
- Inspect flexible hoses, and replace if necessary.
- At the end, check the operation of the machine.

Every 8000 hours



- Replace Electronic drainer service unit

8.2 Troubleshooting



Only qualified personnel should perform troubleshooting and or maintenance operations.

Prior to performing any maintenance or service, be sure that :







- no part of the machine is powered and that it cannot be connected to the mains supply.
- no part of the machine is under pressure and that it cannot be connected to the compressed air system.
- maintenance personnel have read and understand the safety and operation instructions in this manual.



Before attempting any maintenance operation on the dryer, shut it down and wait at least 30 minutes. Some components can reach high temperature during operation. Avoid contact until system or component has dissipated heat.

SYMPTOM	POSSIBLE CAUSE - SUGGESTED ACTION
◆ The dryer doesn't start.	<ul style="list-style-type: none"> ⇒ Verify that the system is powered. ⇒ Verify the electric wiring. ⇒ ACT 200-500 3phase - Blow of fuse (FU3 on the electric diagram) of the auxiliary circuit - replace it and check the proper operation of the dryer.
◆ The compressor doesn't work.	<ul style="list-style-type: none"> ⇒ Activation of the compressor internal thermal protection - wait for 30 minutes, then retry. ⇒ Verify the electric wiring. ⇒ If installed - Replace the internal thermal protection and/or the start-up relay and/or the start-up capacitor and/or the working capacitor. ⇒ If installed - The pressure switch HPS has been activated - see specific point. ⇒ If installed - The pressure switch LPS has been activated - see specific point. ⇒ If installed - The safety thermo switch TS has been activated - see specific point ⇒ If the compressor still doesn't work, replace it.
◆ Condenser's fan doesn't work (Air-Cooled).	<ul style="list-style-type: none"> ⇒ Verify the electric wiring. ⇒ PV pressure switch is faulty – replace it ⇒ ACT 200-500 3phase - Blow of fuse (FU1-FU2 on the electric diagram) - replace it and check the proper operation of the dryer. ⇒ There is a leak in the refrigerant circuit - contact a refrigeration engineer. ⇒ If the fan still doesn't work, replace it.
◆ DewPoint too high.	<ul style="list-style-type: none"> ⇒ The dryer doesn't start - see specific point. ⇒ The DewPoint probe T1 doesn't correctly detect the temperature - ensure the sensor is pushed into the bottom of probe well. ⇒ The Compressor doesn't work - see specific point. ⇒ The ambient temperature is too high or the room aeration is insufficient - provide proper ventilation (Air-Cooled). ⇒ The inlet air is too hot - restore nominal conditions. ⇒ The inlet air pressure is too low - restore nominal conditions. ⇒ The inlet air flow rate is higher than the rate of the dryer - reduce the flow rate - restore nominal conditions. ⇒ The condenser is dirty - clean it (Air-Cooled) ⇒ The condenser fan doesn't work - see specific point (Air-Cooled). ⇒ The cooling water is too hot - restore nominal conditions (Water-Cooled). ⇒ The cooling water flow is insufficient - restore nominal conditions (Water-Cooled). ⇒ The dryer doesn't drain the condensate - see specific point. ⇒ The hot gas by-pass valve is out of setting - contact a refrigeration engineer to restore nominal setting. ⇒ There is a leak in the refrigerant circuit - contact a refrigeration engineer.

SYMPTOM	POSSIBLE CAUSE - SUGGESTED ACTION
◆ Dew Point too low	⇒ The fan is always on – PV pressure switch is faulty – replace it (Air-Cooled). ⇒ Ambient temperature is too low - restore nominal conditions (Air-Cooled). ⇒ The hot gas by-pass valve is out of setting - contact a refrigeration engineer to restore nominal setting.
◆ Excessive pressure drop within the dryer.	⇒ The dryer doesn't drain the condensate - see specific point. ⇒ The DewPoint is too low - the condensate is frost and blocks the air - see specific point. ⇒ Check for throttling the flexible connection hoses.
◆ The dryer doesn't drain the condensate	⇒ The condensate drain service valve is closed - open it. ⇒ Condensate strainer is clogged – remove and clean it. ⇒ The drain solenoid valve is jammed – remove and clean it. ⇒ Verify the electric wiring. ⇒ The coil of the drain solenoid valve is failed – replace it. ⇒ Electronic instrument is faulty – replace it. ⇒ The DewPoint is too low - the condensate is frost and blocks the air - see specific point. ⇒ Inlet compressed air pressure is too low and condensate is not drained – restore nominal conditions. ⇒ Electronic drainer is not operating correctly (see paragraph 7.17).
◆ The dryer continuously drains condensate.	⇒ The drain solenoid valve is jammed – remove and clean it. ⇒ Try to remove the electric connector on the solenoid valve - if drain stops verify the electric wiring or the electronic instrument is faulty - replace it ⇒ Electronic drainer is dirty (see paragraph 7.17).
◆ Water within the line.	⇒ The dryer doesn't start - see specific point. ⇒ If installed - Untreated air flows through the by-pass unit - close the by-pass. ⇒ The dryer doesn't drain the condensate - see specific point. ⇒ DewPoint too high - see specific point.
◆ If installed –HPS high pressure switch has been activated.	⇒ Check which of the following has caused the activation : 1. The ambient temperature is too high or the room aeration is insufficient - provide proper ventilation (Air-Cooled). 2. The condenser is dirty - clean it (Air-Cooled). 3. The condenser fan doesn't work - see specific point (Air-Cooled). 4. The cooling water is too hot - restore nominal conditions (Water-Cooled). 5. The cooling water flow is insufficient - restore nominal conditions (Water-Cooled). ⇒ Reset the pressure switch pressing the button on the controller itself - verify the dryer for correct operation. ⇒ HPS pressure switch is faulty - contact a refrigeration engineer to replace it.
◆ If installed – LPS low pressure switch has been activated.	⇒ There is a leak in the refrigerating fluid circuit - contact a refrigeration engineer. ⇒ The pressure switch reset automatically when normal conditions are restored - check the proper operation of the dryer.

SYMPTOM	POSSIBLE CAUSE - SUGGESTED ACTION
<p>◆ If installed – TS safety thermo switch has been activated.</p>	<p>⇒ Check which of the following has caused the activation :</p> <ol style="list-style-type: none"> 1. Excessive thermal load – restore the standard operating conditions. 2. The inlet air is too hot - restore the nominal conditions. 3. The ambient temperature is too high or the room aeration is insufficient - provide proper ventilation (Air-Cooled). 4. The condenser unit is dirty - clean it (Air-Cooled). 5. The fan doesn't work - see specific point (Air-Cooled). 6. The hot gas by-pass valve requires re-adjusting – contact a specialized technician to restore nominal setting. 7. The temperature of the cooling water is too low – restore nominal conditions (Water-Cooled). 8. The cooling water flow adjusting valve requires re-adjusting - contact a specialized technician to restore nominal setting (Water-Cooled). 9. Refrigerant gas leak - contact a refrigeration engineer. <p>⇒ Reset the thermo switch by pressing the button on the thermo switch itself – verify the correct operation of the dryer.</p> <p>⇒ TS thermo switch is faulty - replace it.</p>
<p>◆ Electronic instrument DMC14</p> <p>The led  is on or flashes.</p>	<p>⇒ The led  flashes because the DewPoint is too high – see specific point.</p> <p>⇒ The led  flashes because the DewPoint is too low - see specific point.</p> <p>⇒ The led  is on because the probe is faulty or interrupted, the instrument displays the message “PF” (Probe Failure) – replace the probe.</p>

Maintenance, troubleshooting, spare parts and dismantling

8.3 Spare parts

Spare parts list is printed on a dedicated sticker applied inside the dryer. On this sticker each spare part is identified with its ID Number and related Spare Part Number. Here below the cross reference table between ID Numbers and exploded drawings Ref. with their description and quantity installed in the dryers.

ID N.	DESCRIPTION	ACT-UP & ACT-UE												
		20	30	50	75	100	125	150	200	250	300	350	400	500
2	LPS Pressure switch										1	1	1	1
3	TS Safety thermo switch						1	1	1	1	1	1	1	1
4	HPS Pressure switch										1	1	1	1
6	MC Compressor	1	1	1	1	1	1	1	1	1	1	1	1	1
7	Hot gas by-pass valve	1	1	1	1	1	1	1	1	1	1	1	1	1
9	MV Complete fan										1	1	1	1
9.1	MV Fan motor	1	1	1	1	1	1	1	1	1				
9.2	Fan blade	1	1	1	1	1	1	1	1	1				
9.3	Fan grid			1	1	1	1	1	1	1				
10	Filter drier	1	1	1	1	1	1	1	1	1	1	1	1	1
12	BT Temperature probe	1	1	1	1	1	1	1	1	1	1	1	1	1
13-14	Condensate drain valve/strainer	1	1	1	1	1								
14	Y strainer						1	1	1	1	1	1	1	1
15	EVD Condensate drain solenoid valve	1	1	1	1	1	1	1	1	1	1	1	1	1
16	Coil for condensate drain solenoid valve	1	1	1	1	1	1	1	1	1	1	1	1	1
17	DMC34 Electronic instrument	1	1	1	1	1	1	1	1	1	1	1	1	1
19	Water regulating valve (water cooled)								1	1	1	1	1	1
21	ELD Electronic drainer	1	1	1	1	1	1	1	1	1	1	1	1	1
	Service unit for electronic drainer	1	1	1	1	1	1	1	1	1	1	1	1	1
22	S1 Lighted switch	1	1	1	1	1								
	QS Main switch						1	1	1	1	1	1	1	1
37	BP2 Pressure transducer	1	1	1	1	1	1	1	1	1	1	1	1	1

ID N.	DESCRIPTION	ACT-UR & ACT-UF					
		200	250	300	350	400	500
2	LPS Pressure switch	1	1	1	1	1	1
3	TS Safety thermo switch	1	1	1	1	1	1
4	HPS Pressure switch	1	1	1	1	1	1
6	MC Compressor	1	1	1	1	1	1
7	Hot gas by-pass valve	1	1	1	1	1	1
9	MV Complete fan	1	1	1	1	1	1
10	Filter drier	1	1	1	1	1	1
12	BT Temperature probe	1	1	1	1	1	1
14	Y strainer	1	1	1	1	1	1
15	EVD Condensate drain solenoid valve	1	1	1	1	1	1
16	Coil for condensate drain solenoid valve	1	1	1	1	1	1
17	DMC34 Electronic instrument	1	1	1	1	1	1
19	Water regulating valve (water cooled)	1	1	1	1	1	1
21	ELD Electronic drainer	1	1	1	1	1	1
	Service unit for electronic drainer	1	1	1	1	1	1
22	S1 Lighted switch	1	1	1	1	1	1
	Cover for lighted switch	1	1	1	1	1	1
	QS Main switch	1	1	1	1	1	1
37	BP2 Pressure transducer	1	1	1	1	1	1
60	FU Fuse kit	1	1	1	1	1	1
	KC1 Contactor	1	1	1	1	1	1
	TF Transformer	1	1	1	1	1	1

8.4 Maintenance operation on the refrigeration circuit



Maintenance and service on refrigerating systems must be carried out only by certified refrigerating engineers only, according to local rules.

All the refrigerant of the system must be recovered for its recycling, reclamation or destruction.

Do not dispose the refrigerant fluid in the environment.

This dryer comes ready to operate and filled with R134a or R407C type refrigerant fluid.



In case of refrigerant leak contact a certified refrigerating engineer. Room is to be aired before any intervention.

If is required to re-fill the refrigerating circuit, contact a certified refrigerating engineers.

Refer to the dryer nameplate for refrigerant type and quantity.

Characteristics of refrigerants used:

Refrigerant	Chemical formula	TLV	GWP
R134a - HFC	CH ₂ FCF ₃	1000 ppm	1430
R407C - HFC	R32/125/134a (23/25/52) CHF ₂ CF ₃ /CH ₂ F ₂ /CH ₂ FCF ₃	1000 ppm	1773.85

8.5 Dismantling of the dryer

If the dryer is to be dismantled, it has to be split into homogeneous groups of materials.



Part	Material
Refrigerant fluid	R407C, R134a, Oil
Canopy and Supports	Carbon steel, Epoxy paint
Refrigerating compressor	Steel, Copper, Aluminium, Oil
Alu-Dry Module	Aluminium
Condenser Unit	Aluminium, Copper, Carbon steel
Pipe	Copper
Fan	Aluminium, Copper, Steel
Valve	Brass, Steel
Electronic Level Drain	PVC, Aluminium, Steel
Insulation Material	Synthetic rubber without CFC, Polystyrene, Polyurethane
Electric cable	Copper, PVC
Electric Parts	PVC, Copper, Brass



We recommend to comply with the safety rules in force for the disposal of each type of material.

Refrigerant contains droplets of lubrication oil released by the refrigerating compressor.

Do not dispose this fluid in the environment. It has to be discharged from the dryer with a suitable device and then delivered to a collection centre where it will be processed to make it reusable.

9 Attachments

Exploded views – List of components

- | | |
|--|---|
| <ul style="list-style-type: none"> 1 Alu-Dry module 1.1 Insulation material 2 Refrigerant pressure switch LPS 3 Safety thermo switch TS 4 Refrigerant pressure switch HPS 6 Compressor 7 Hot-gas bypass valve 8 Condenser (Air-Cooled) 9 Condenser fan (Air-Cooled) 9.1 Motor 9.2 Blade 9.3 Grid 10 Filter dryer 11 Capillary tube 12 Temperature probe 13 Condensate drain service valve 14 Condensate drain strainer 15 Condensate drain solenoid valve 16 Coil for condensate drain solenoid valve 17 Electronic instrument 18 Condenser (Water-Cooled) | <ul style="list-style-type: none"> 19 Condenser water-regulating valve (Water-Cooled) 20 Refrigerant accumulator 21 Electronic drainer 22 Main switch 37 Pressure transducer BP2 51 Front panel 52 Back panel 53 Right lateral panel 54 Left lateral panel 55 Cover 56 Base plate 57 Upper plate 58 Support beam 59 Support bracket 60 Control panel 61 Electric connecting plug 62 Electric box 66 QE door 81 Flow diagram sticker |
|--|---|

Electric diagrams – List of components

- | | |
|--|---|
| <ul style="list-style-type: none"> MC1 Compressor KT Compressor thermal protection KR Compressor starting relay CS Compressor starting capacitor CR Compressor operating capacitor MV1 Condenser fan KV Fan thermal protection CV Fan starting capacitor DMC34 Electronic instrument BT1 Temperature probe LPS Low pressure switch | <ul style="list-style-type: none"> HPS High pressure switch BP2 Pressure transducer TS Safety thermo switch EVD Timed condensate drain solenoid valve ELD Electronic drainer S1 ON-OFF switch QS Main switch with door block RC Compressor crankcase heater BOX Electrical box TR Autotransformer |
|--|---|

- | | |
|---|--|
| <ul style="list-style-type: none"> NT1 Air-Cooled only NT2 Verify transformer connection according to power supply voltage NT3 Jump if not installed NT4 Provided and wired by customer | <ul style="list-style-type: none"> NT5 Limit of equipment NT6 Timed drain output NT7 Water Cooled only |
|---|--|

- | | |
|--|--|
| <ul style="list-style-type: none"> BN Brown BU Blue BK Black YG Yellow / Green | <ul style="list-style-type: none"> OR Orange RD Red WH White WH/BK White / Black |
|--|--|

9.1 Dryers dimensions

9.1.1 ACT 20 – 50

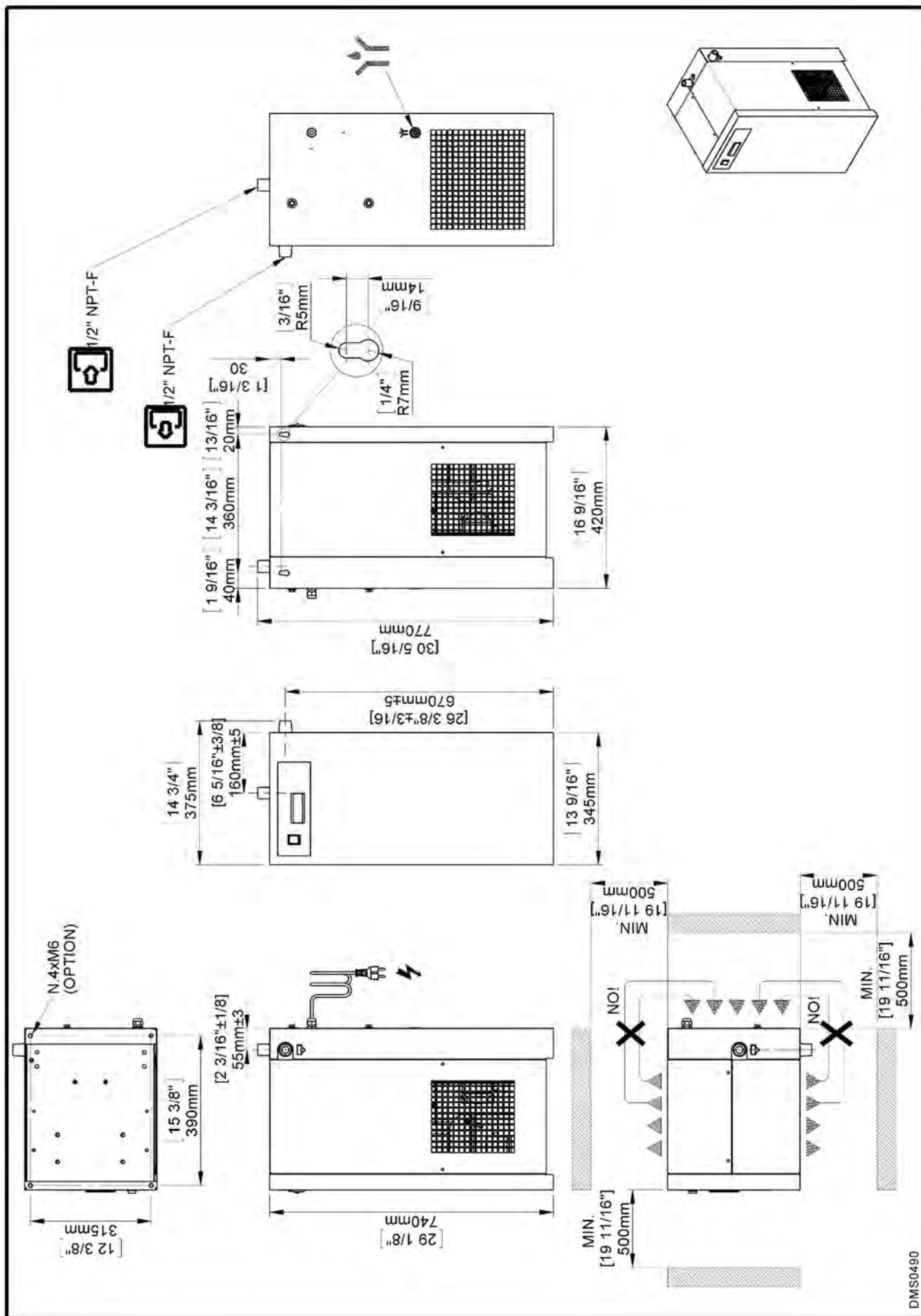

DMS0490

9.1.2 ACT 75

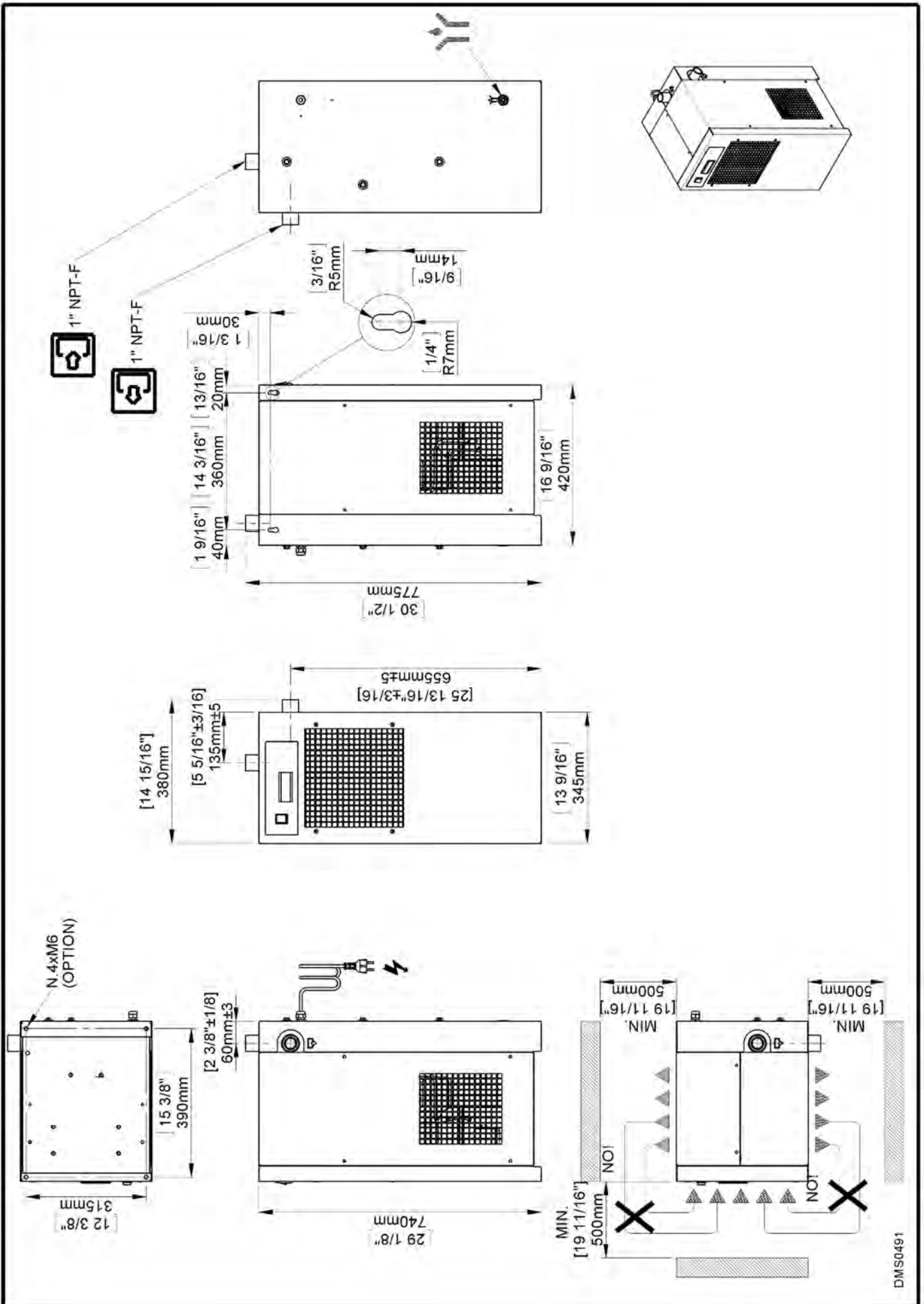

DMS0491

9.1.4 ACT 200 – 250

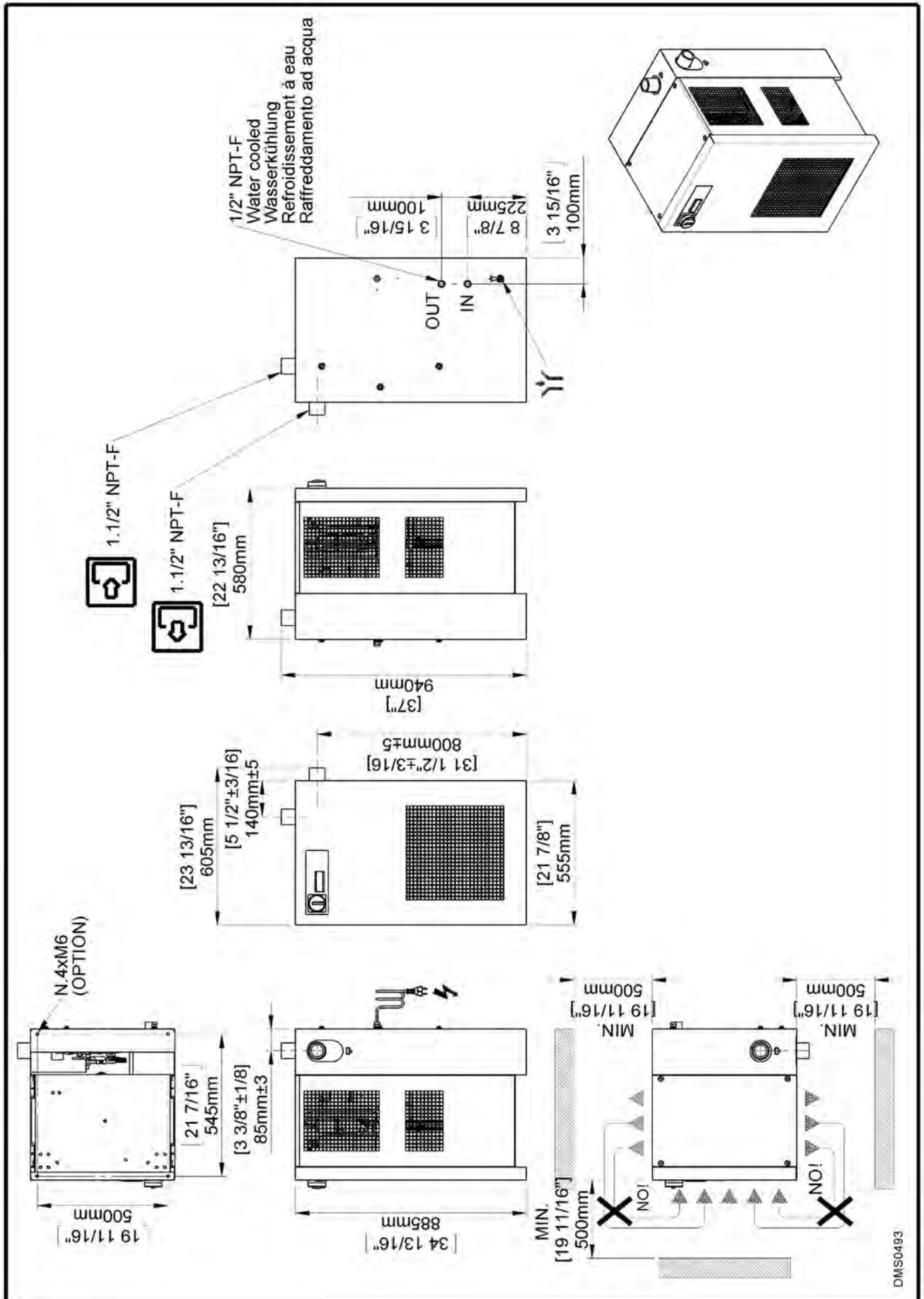

9.1.5 ACT 300 – 350

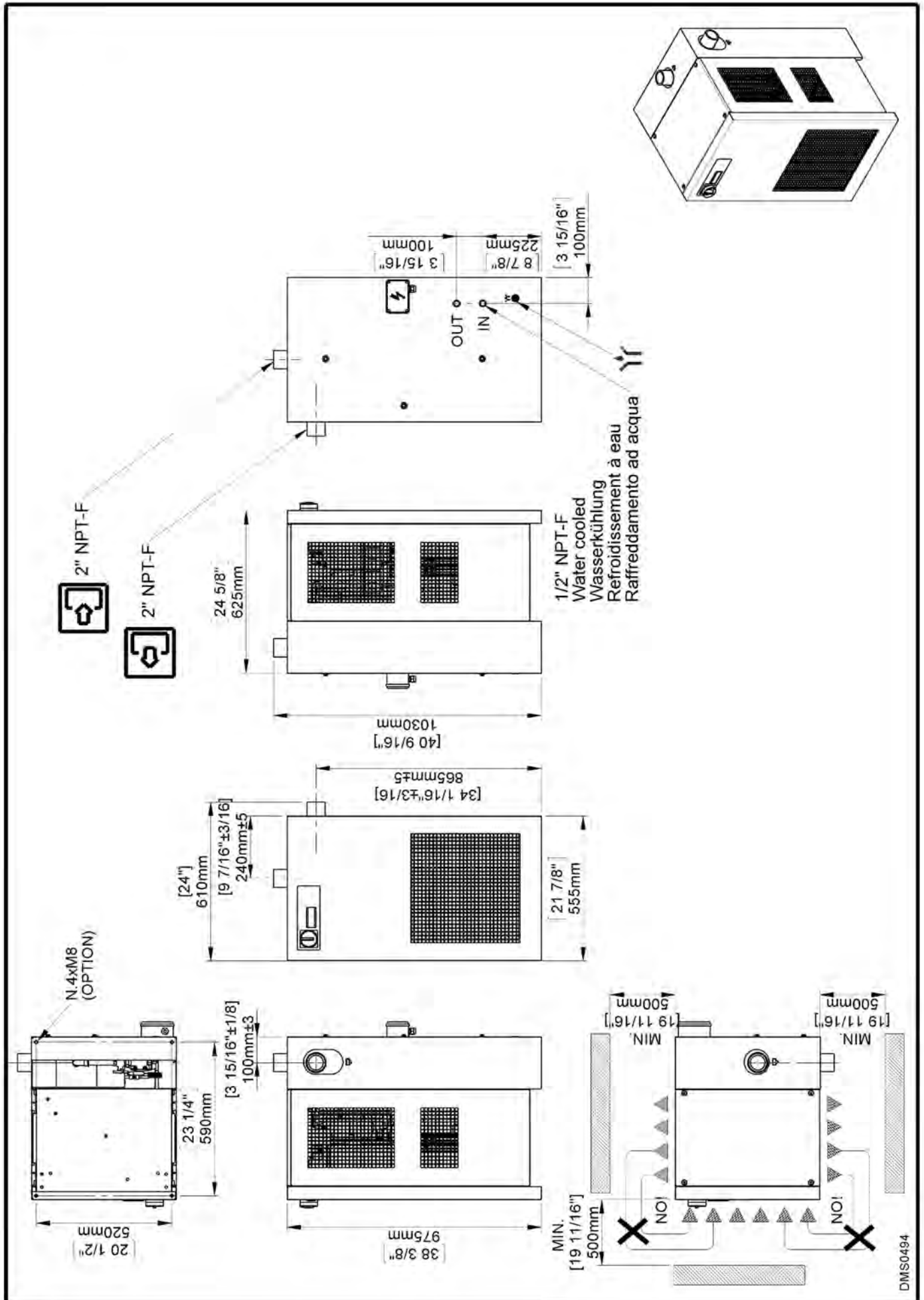

9.1.6 ACT 400 – 500

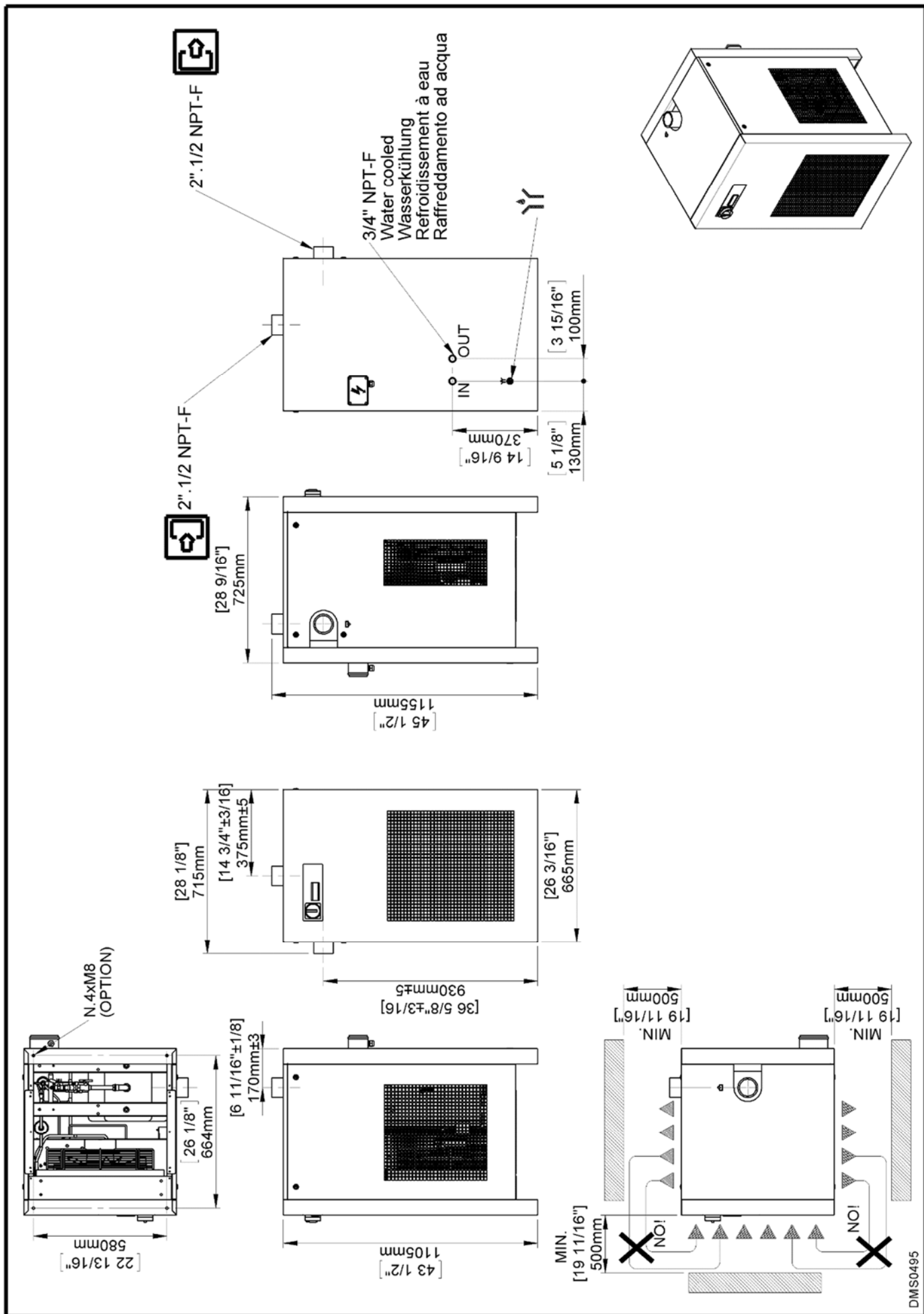

9.1.7 ACT 200 – 250 3phase

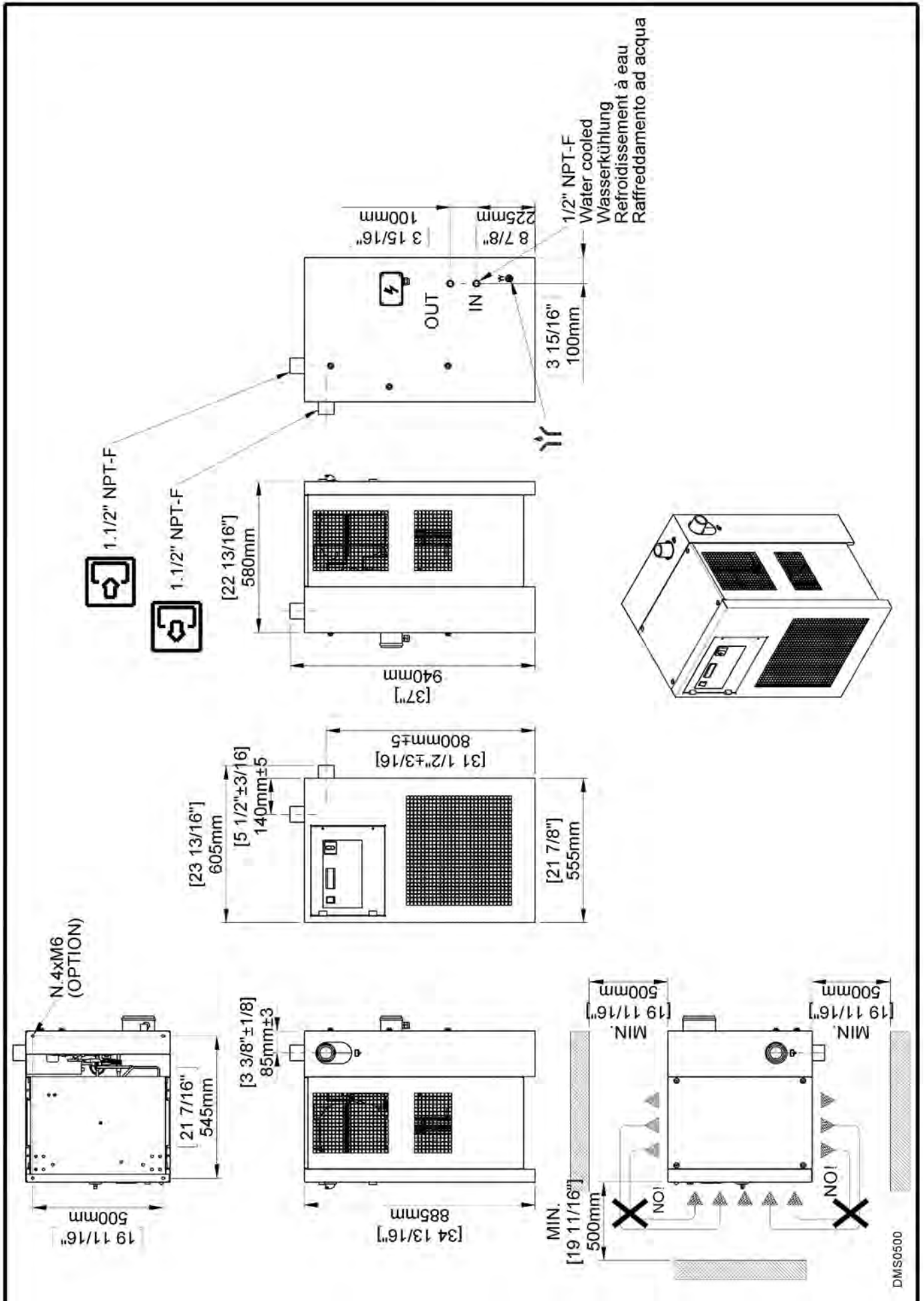

Attachments

9.1.8 ACT 300 – 350 3phase

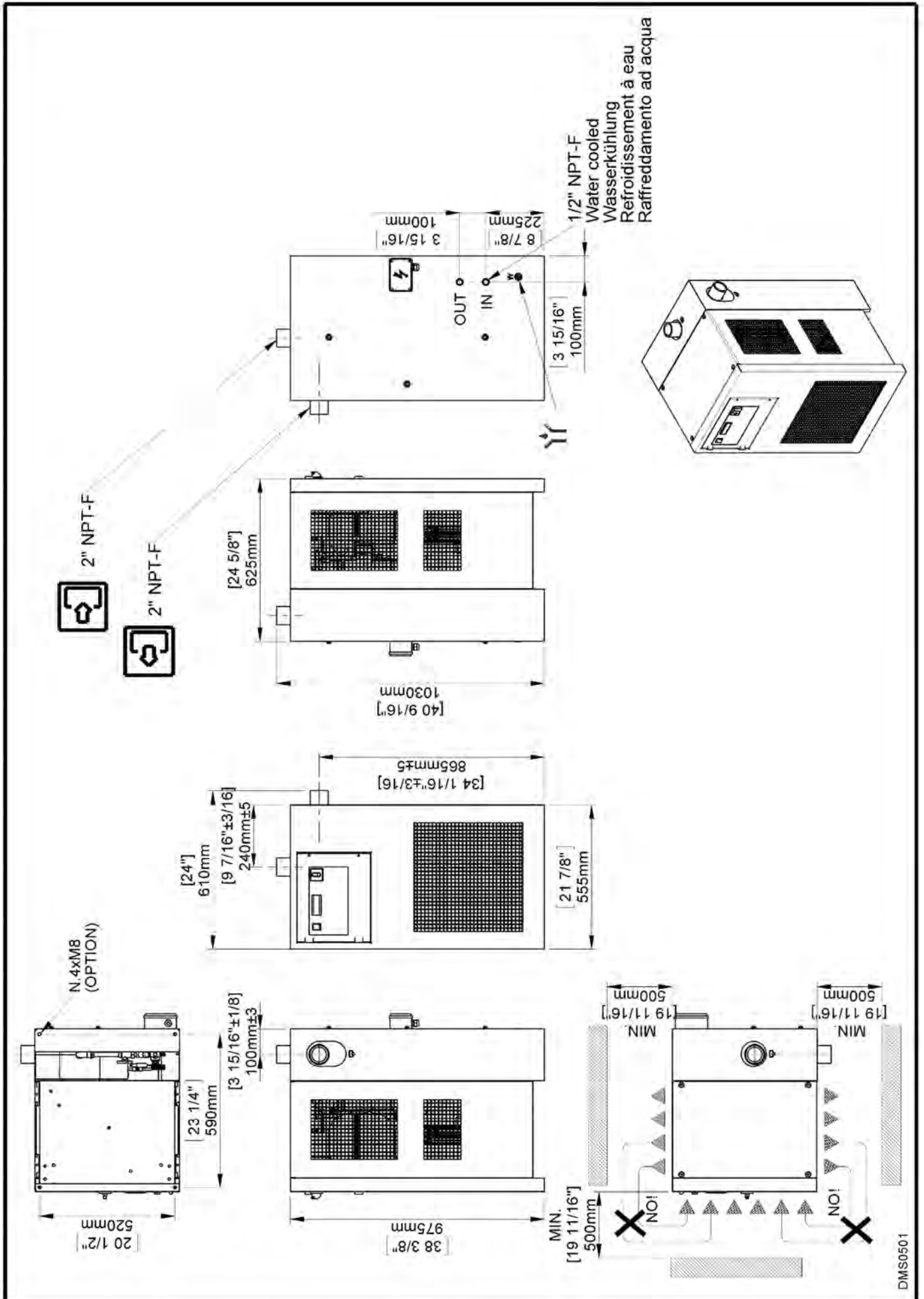

9.1.9 ACT 400 – 500 3phase

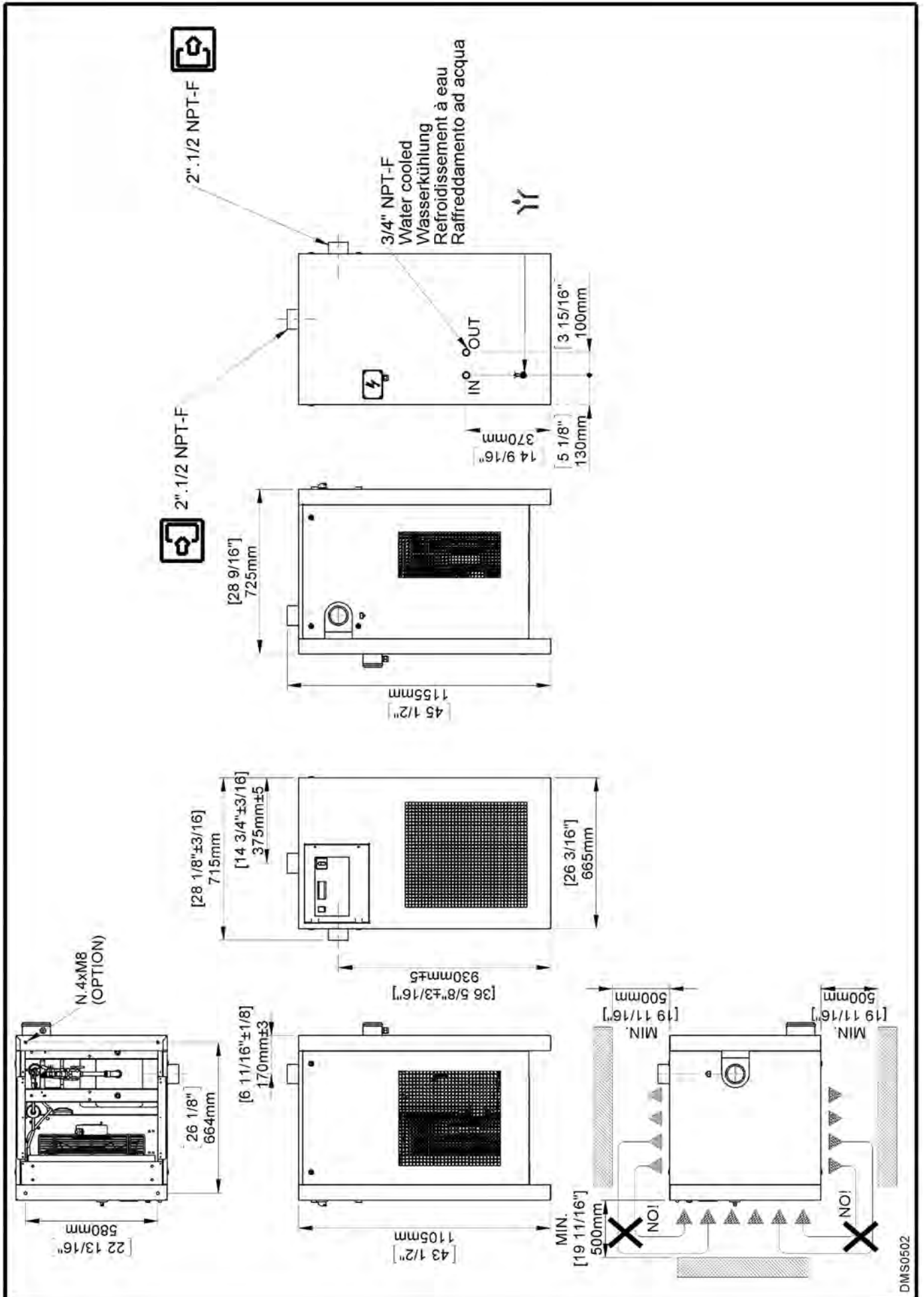

9.2 Exploded views

9.2.1 ACT 20 – 30

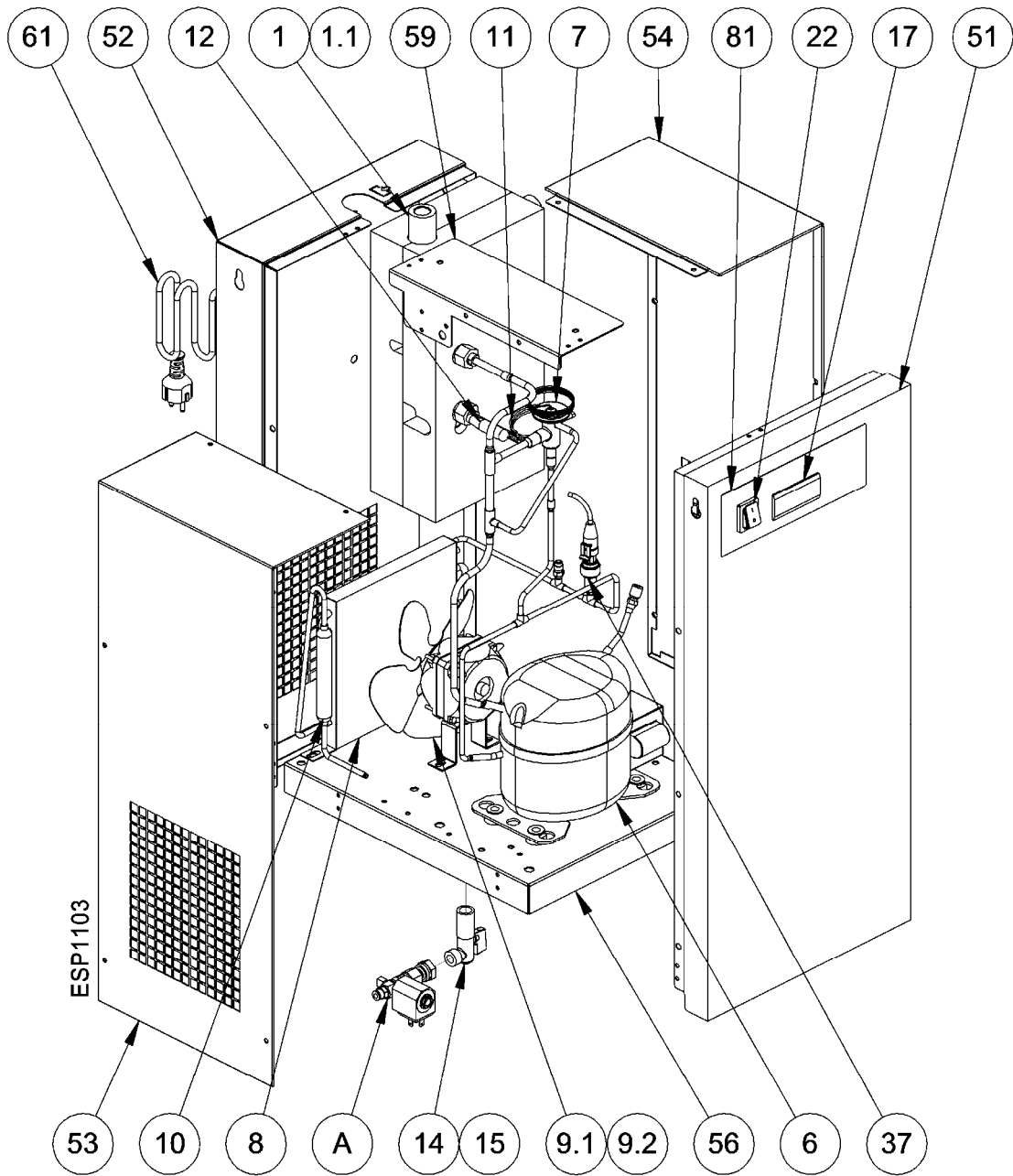

Pos.A Standard

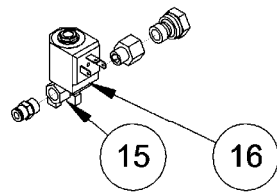

Pos.A Optional

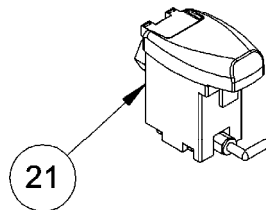

9.2.2 ACT 50

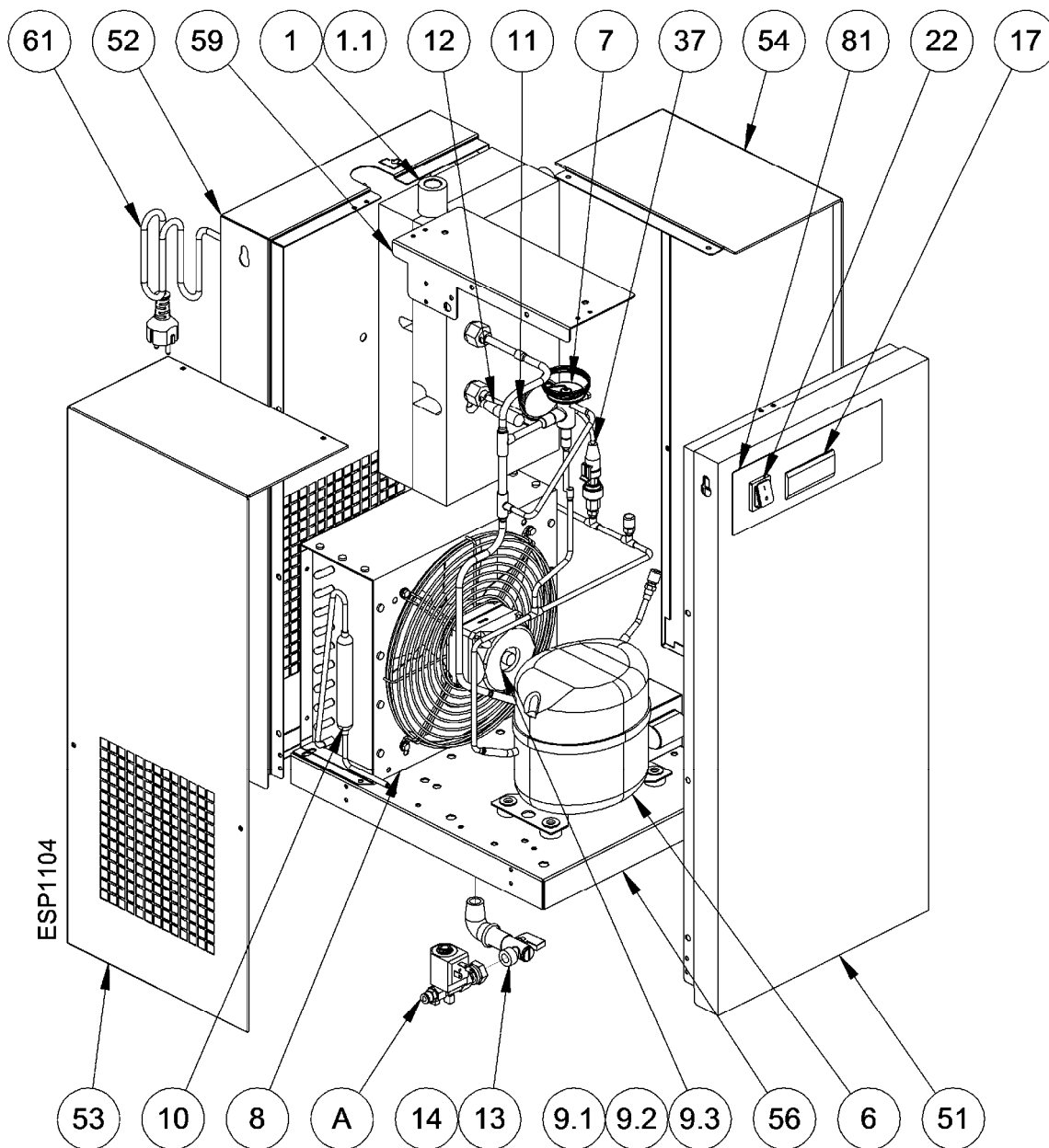

Pos.A Standard

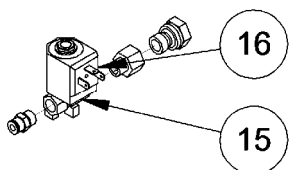

Pos.A Optional

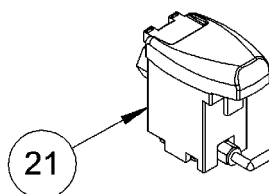

9.2.3 ACT 75

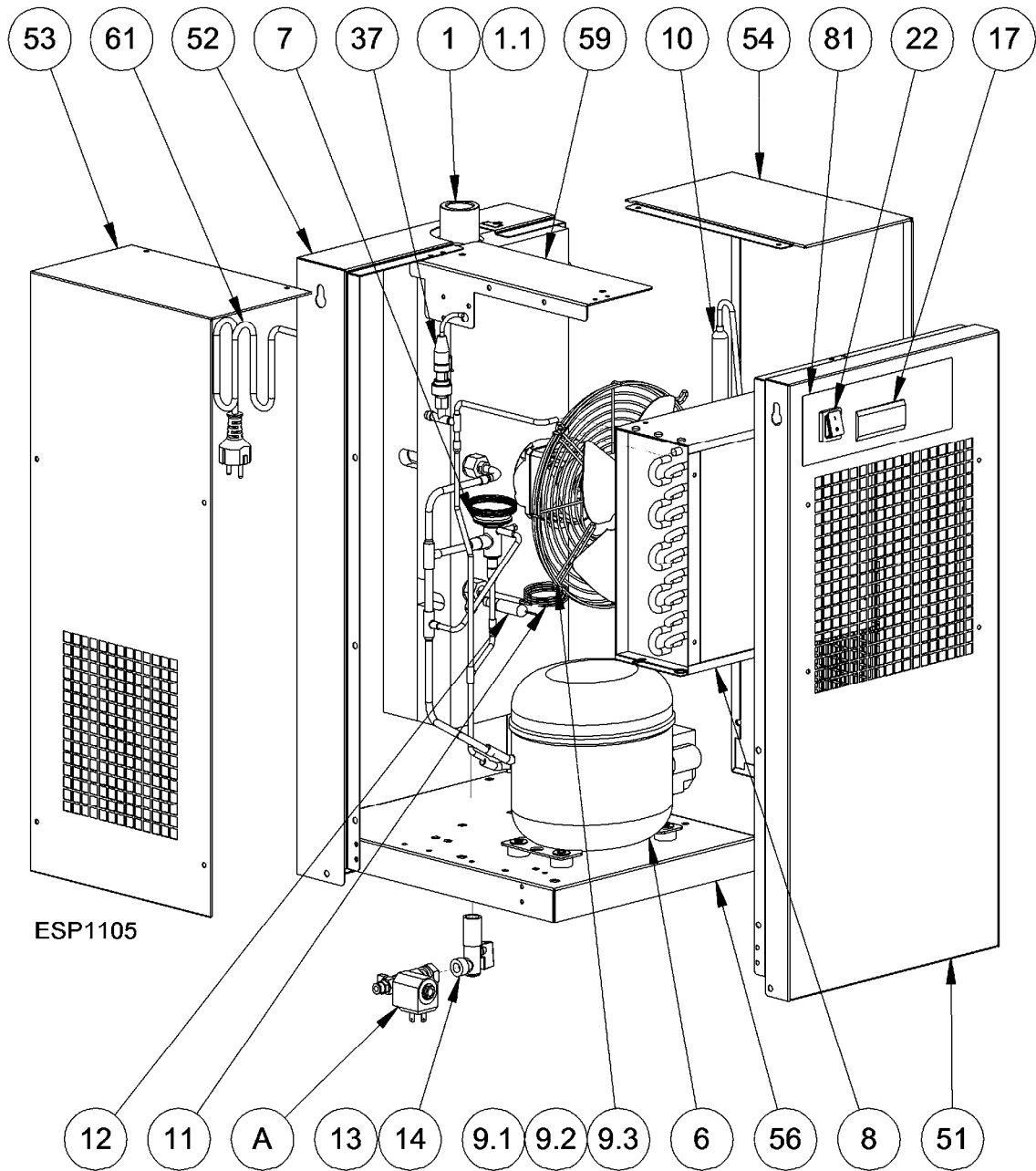

Pos.A Standard

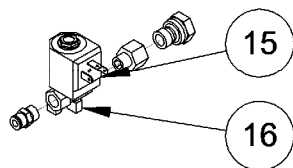

Pos.A Optional

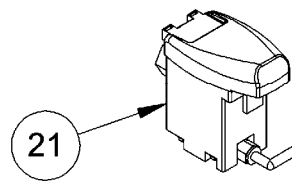

9.2.4 ACT 100

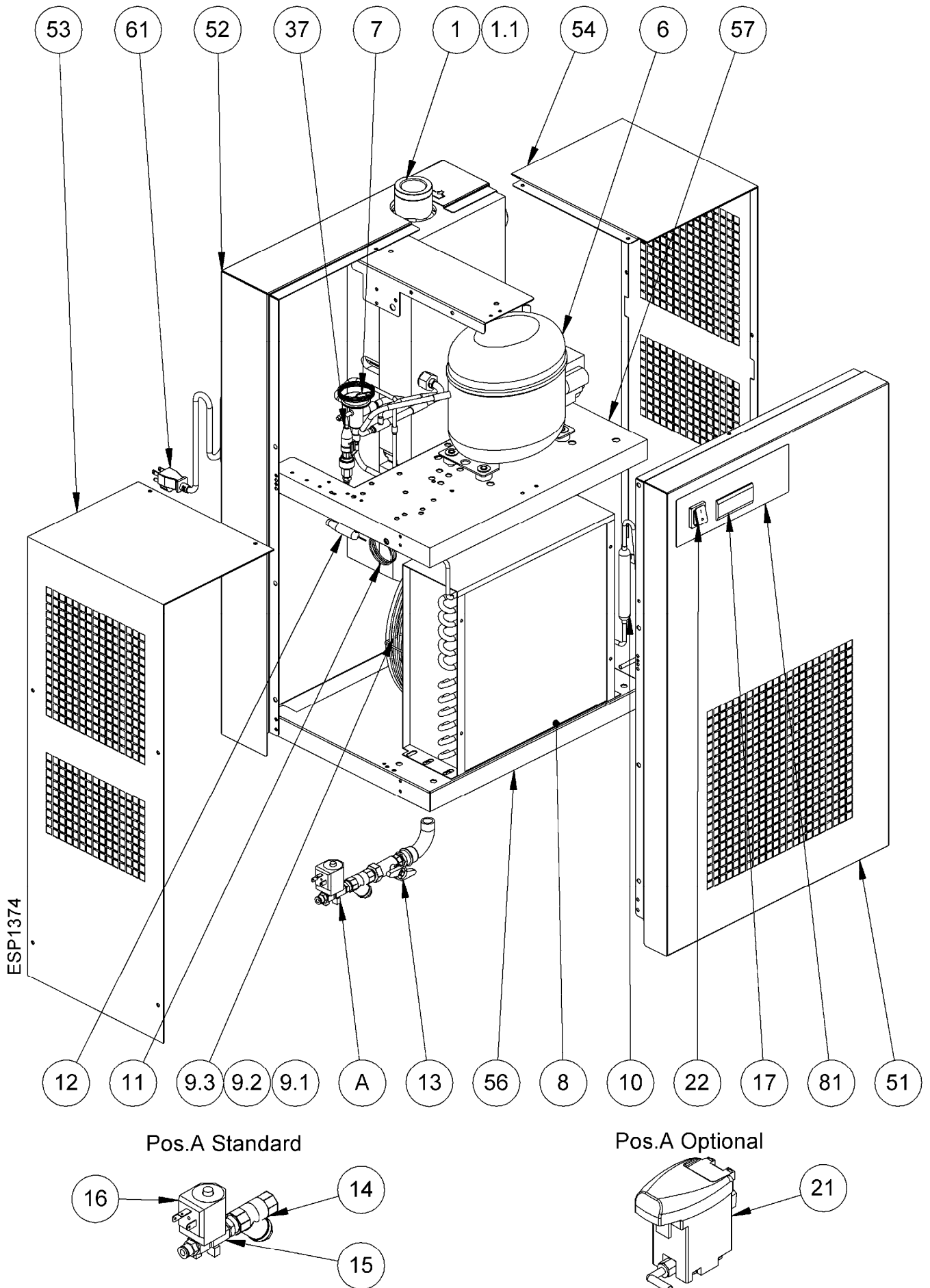

9.2.5 ACT 125 – 150

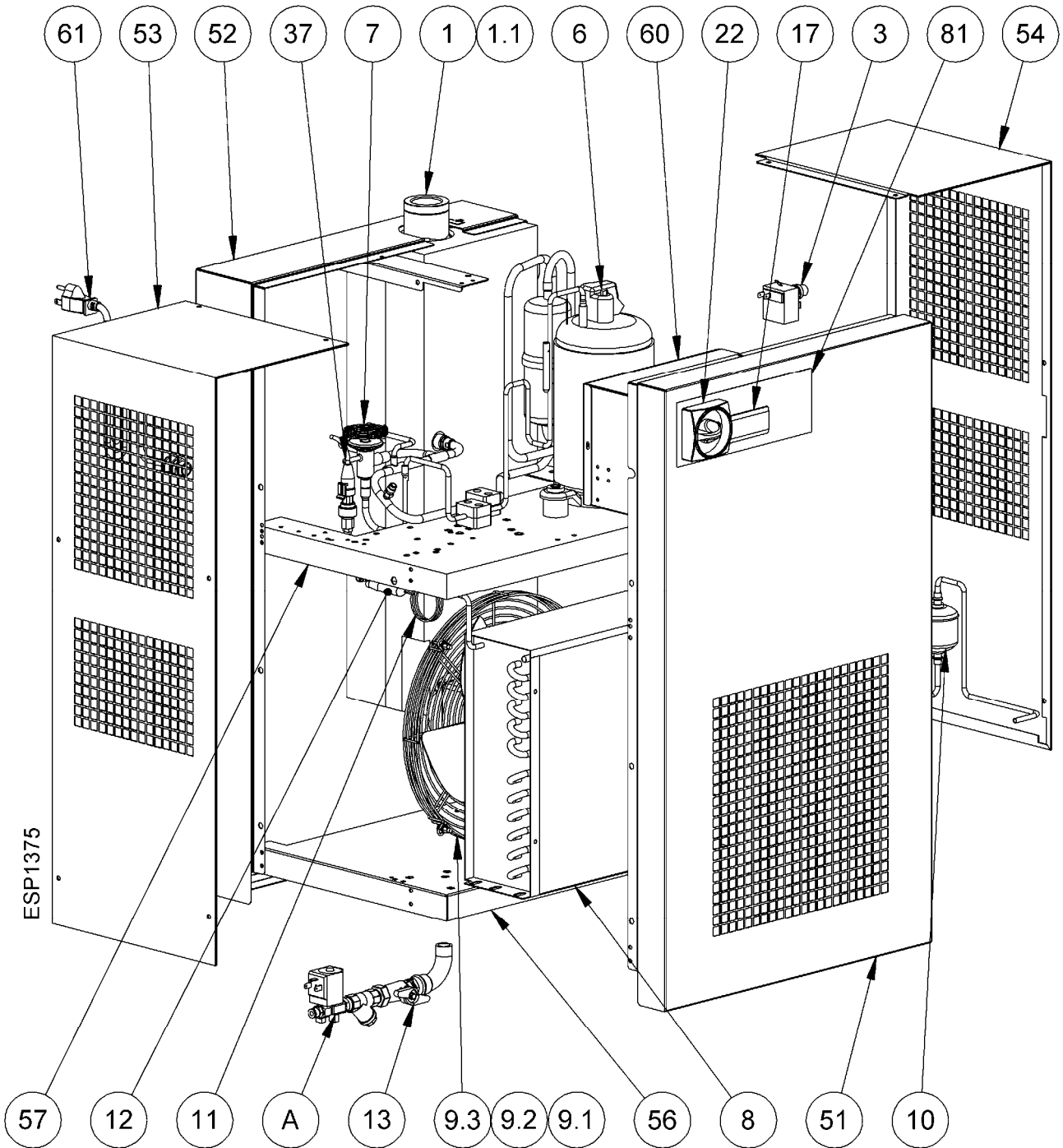

Pos.A Standard

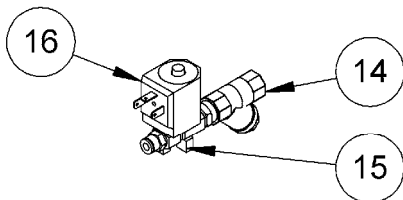

Pos.A Optional

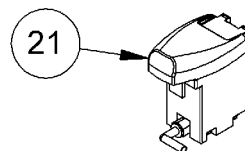

9.2.6 ACT 200 – 250 Air Cooled

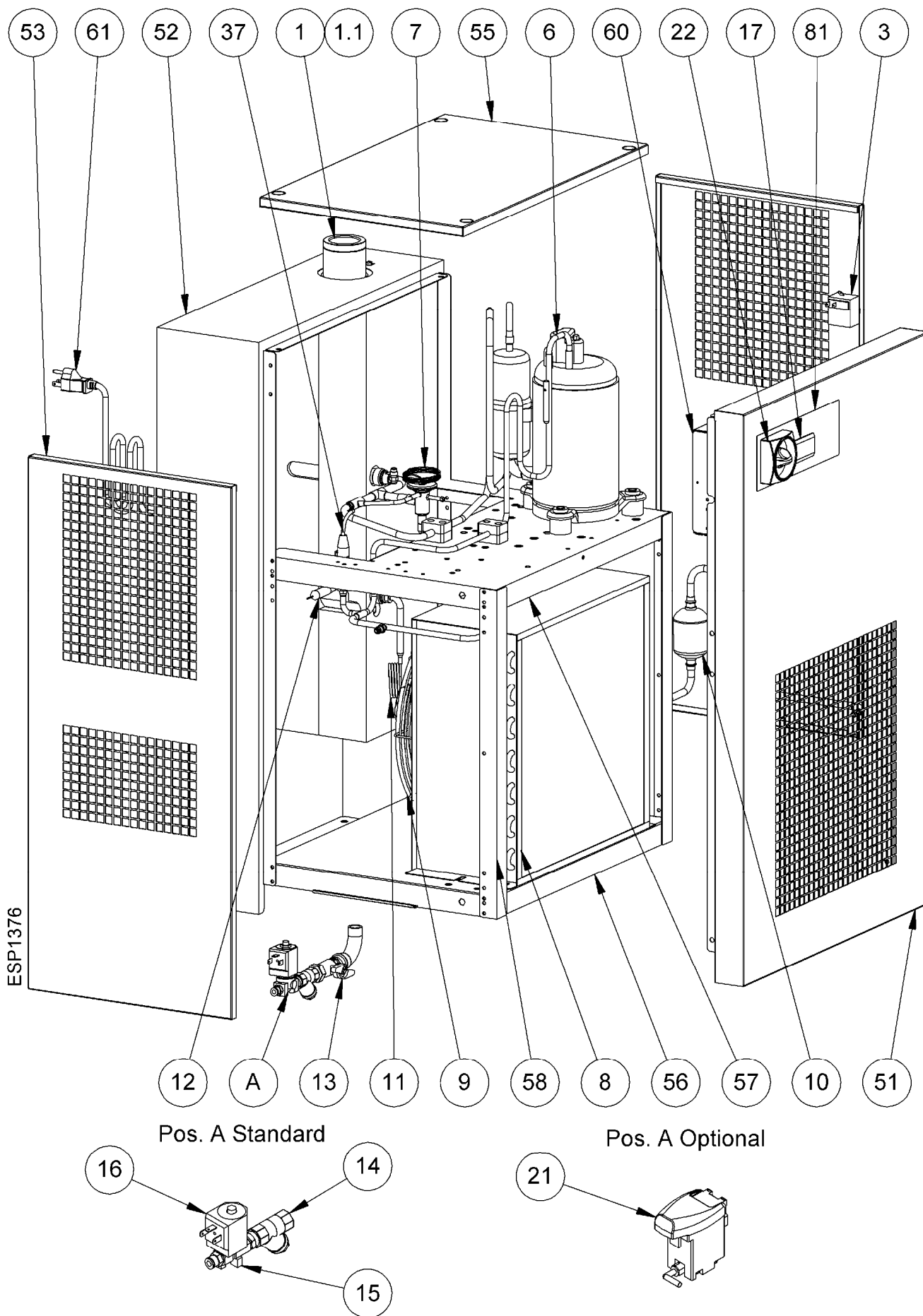

9.2.7 ACT 200 – 250 Water Cooled

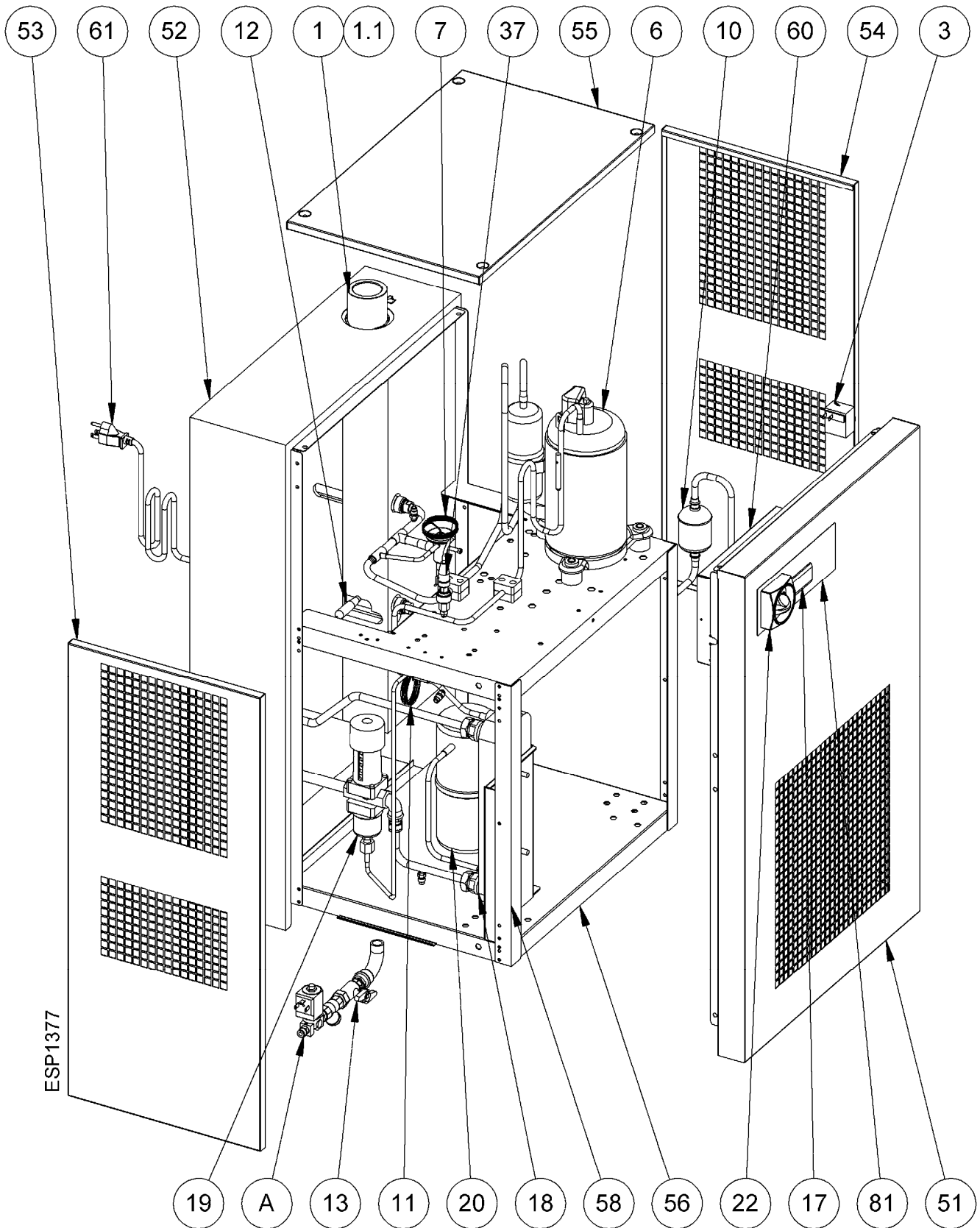

Pos.A Standard

Pos.A Optional

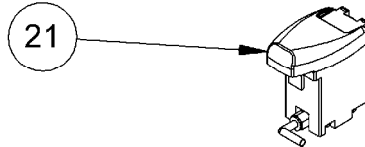
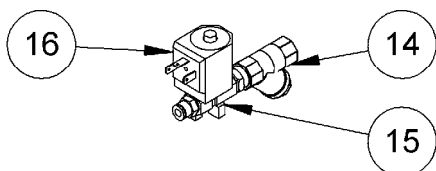

9.2.8 ACT 300 – 350 Air Cooled

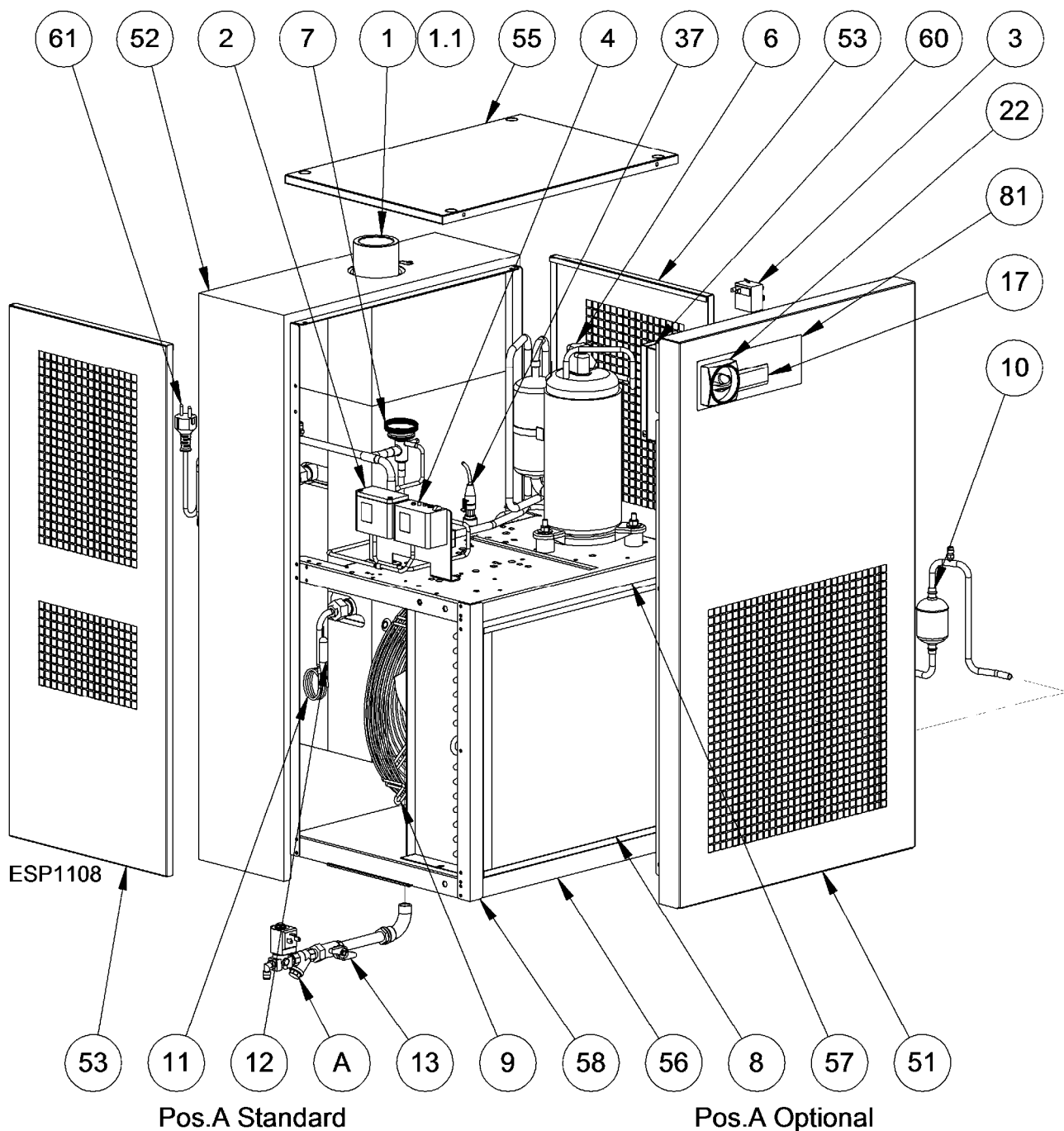

9.2.9 ACT 300 – 350 Water Cooled

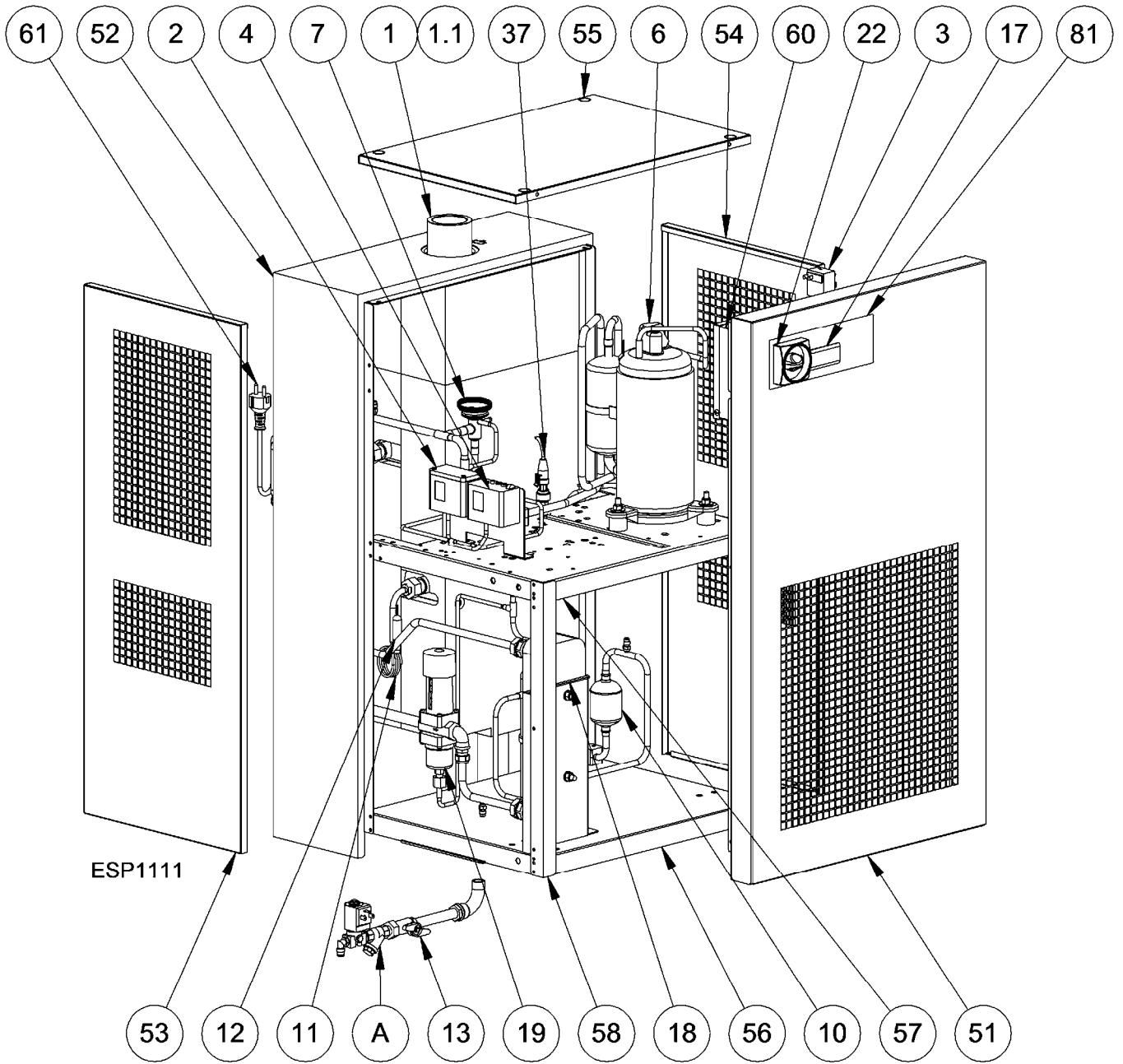

Pos.A Standard

Pos.A Optional

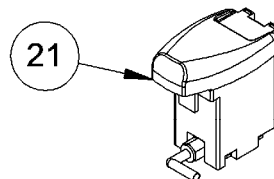
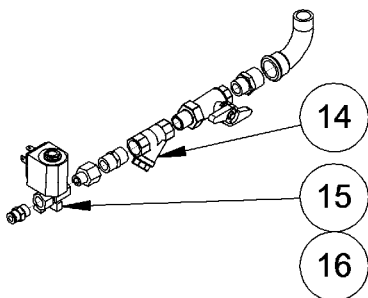

9.2.10 ACT 400 – 500 Air Cooled

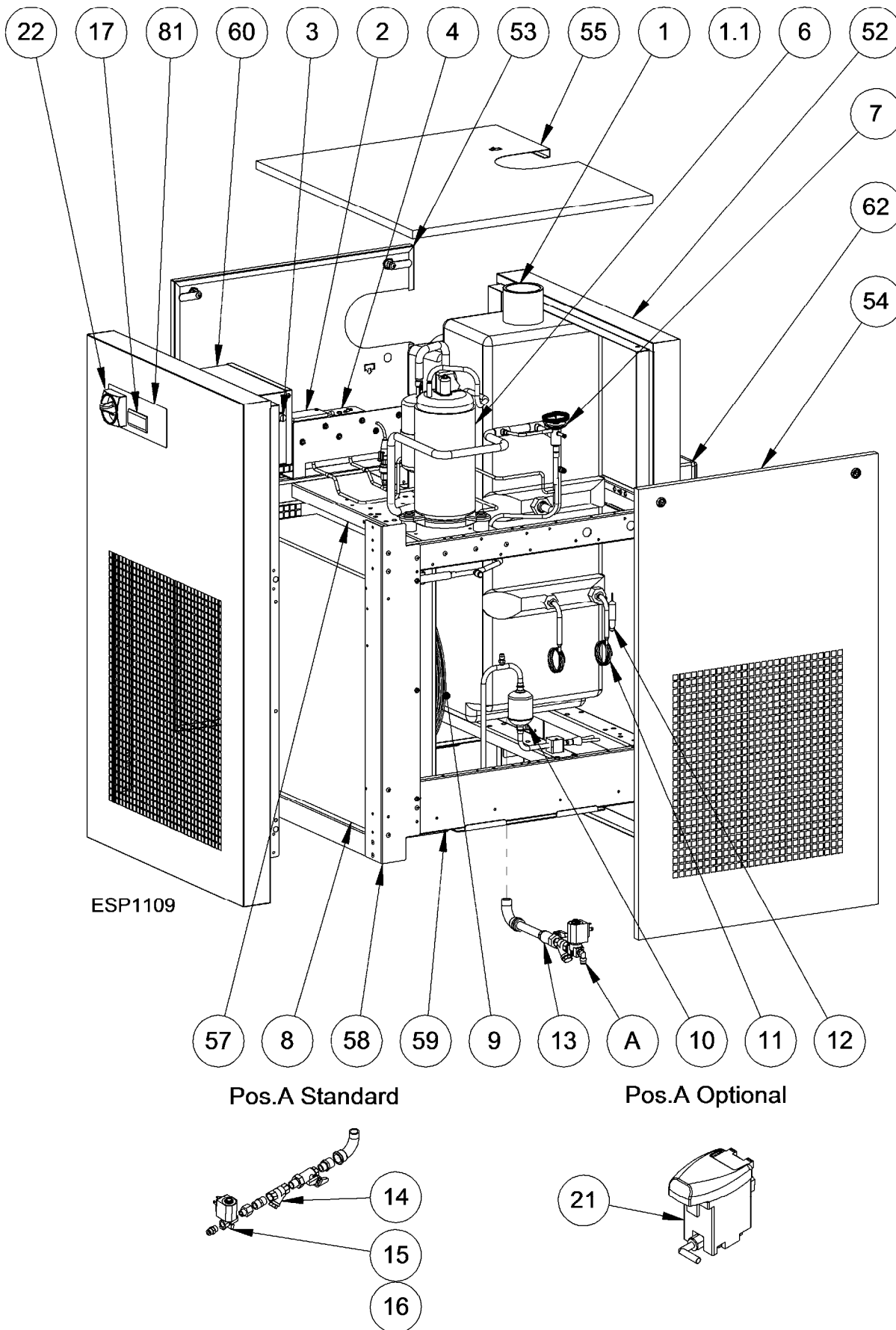

9.2.11 ACT 400 – 500 Water Cooled

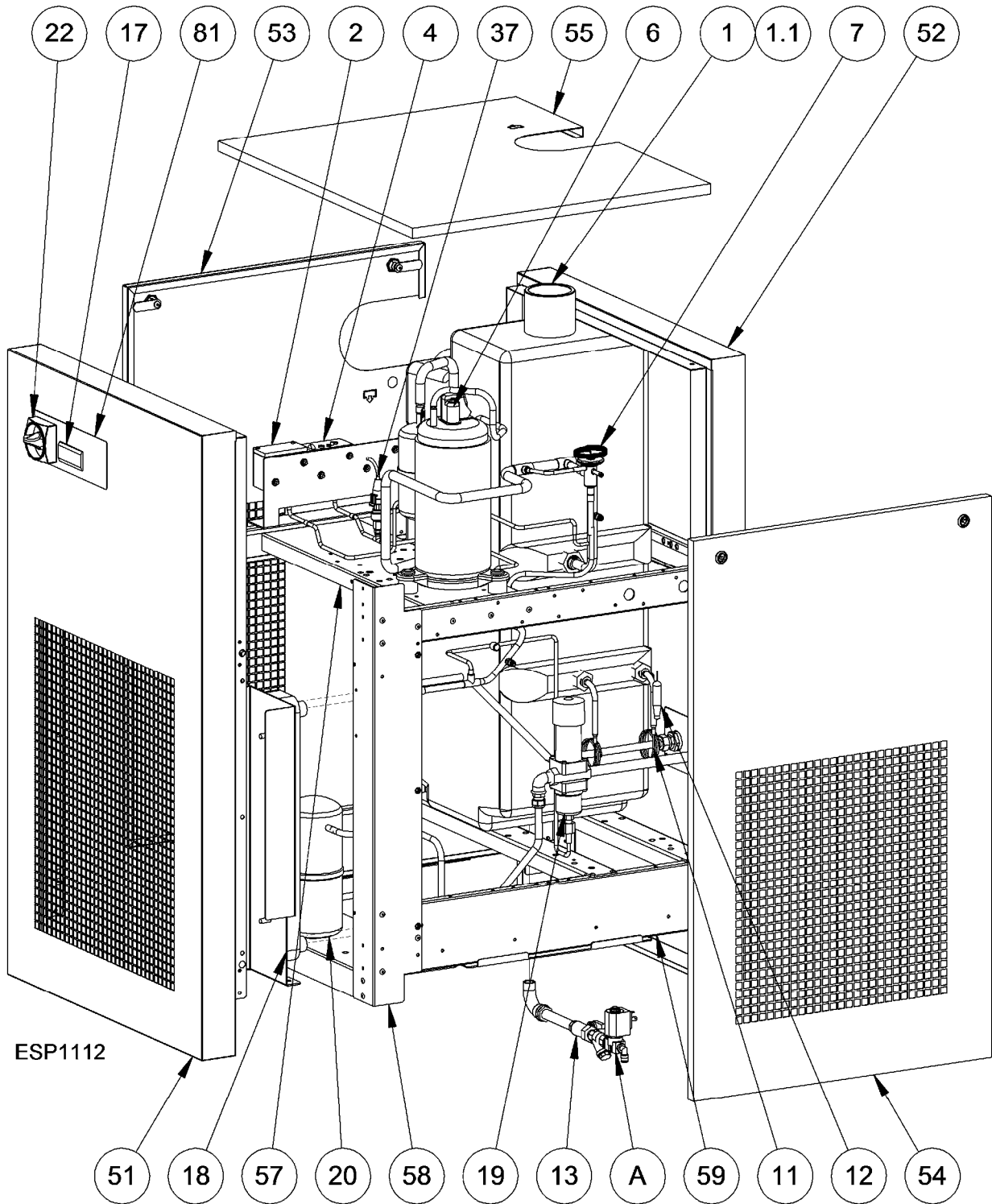

Pos.A Standard

Pos.A Optional

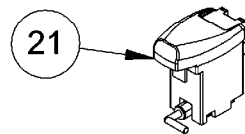
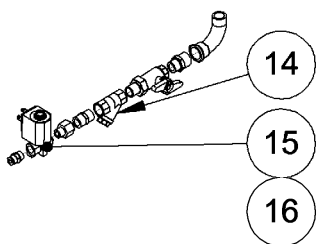

9.2.12 ACT 200 – 250 3phase Air Cooled

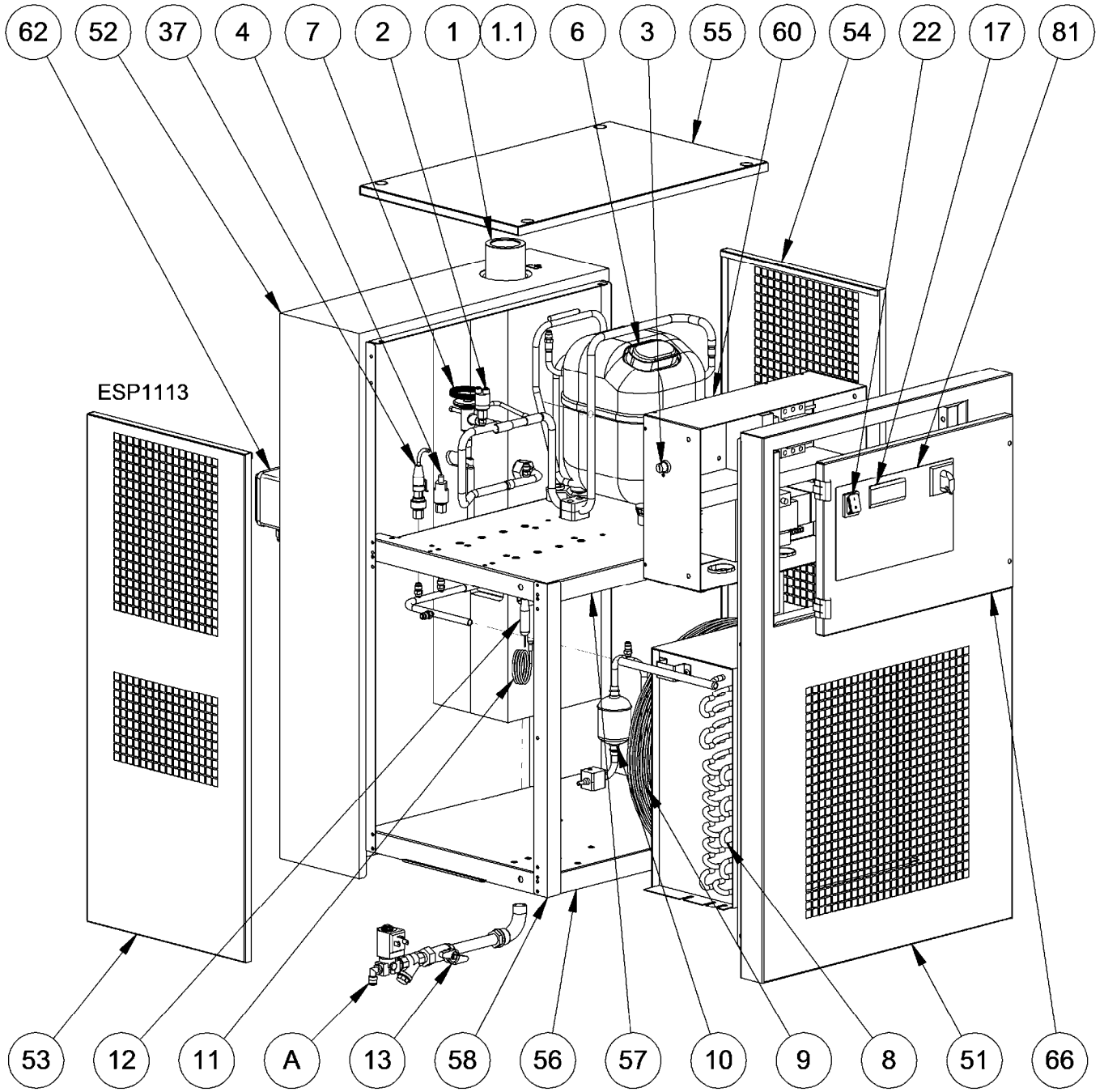

Pos.A Standard

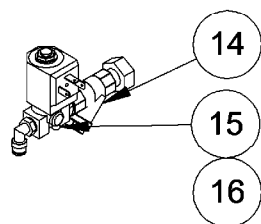

Pos.A Optional

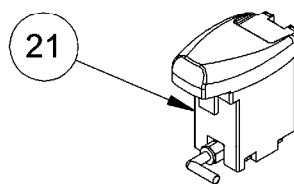

9.2.13 ACT 200 – 250 3phase Water Cooled

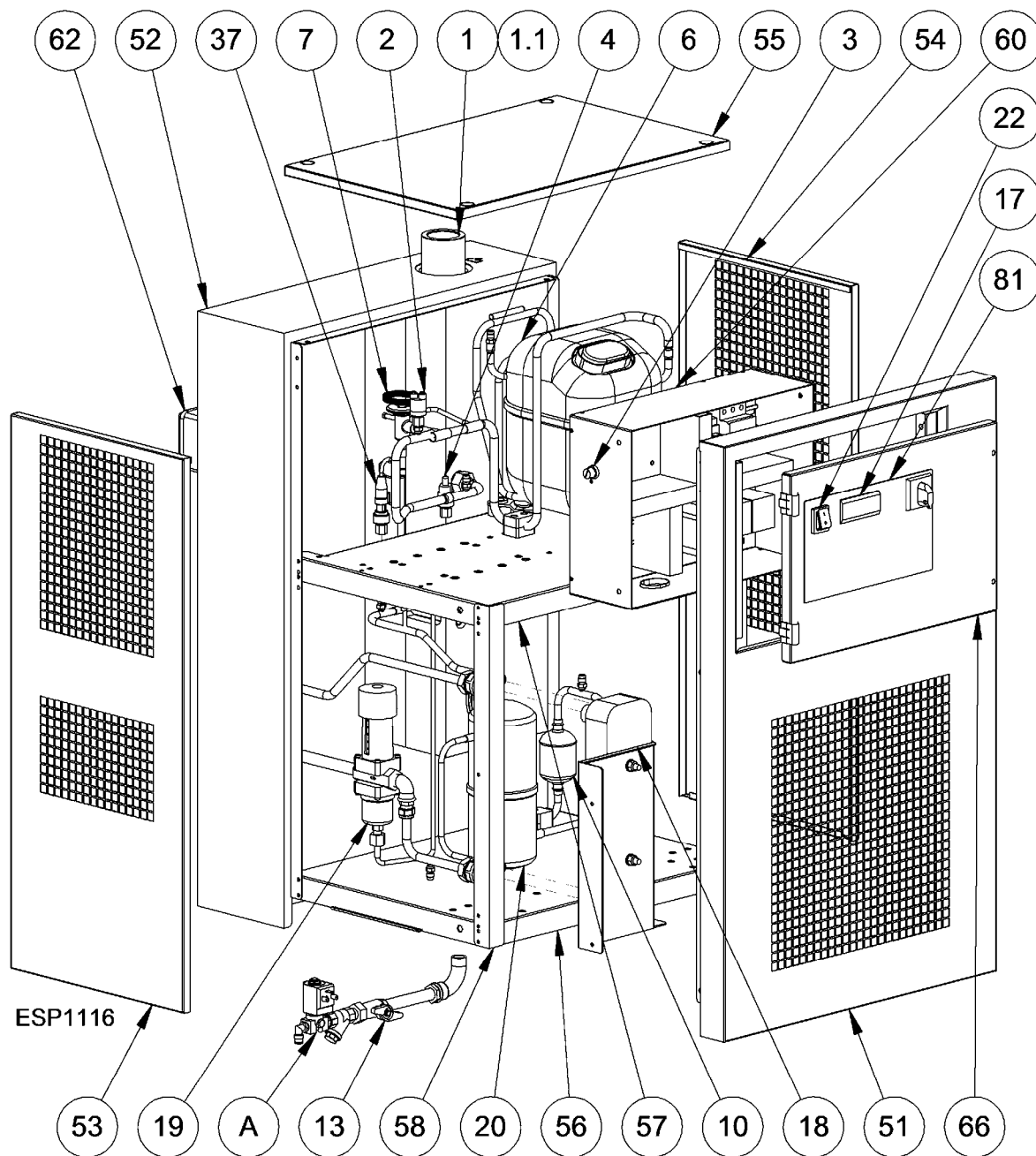

Pos.A Standard

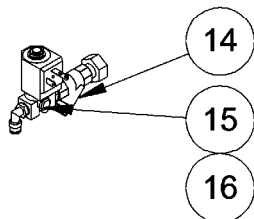

Pos.A Optional

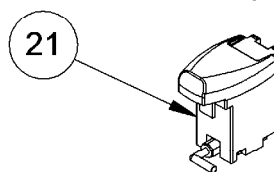

9.2.14 ACT 300 – 350 3phase Air Cooled

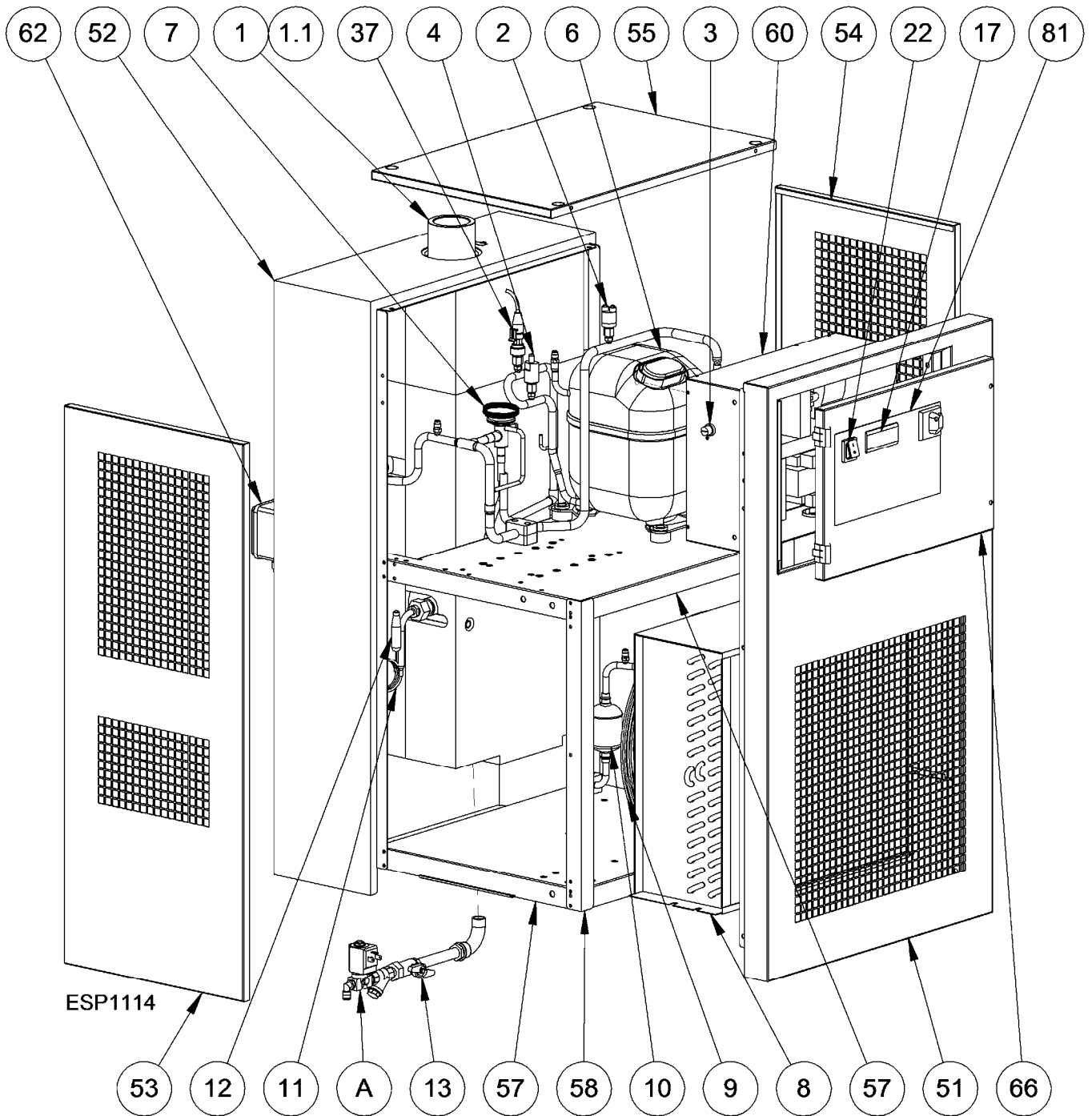

Pos.A Standard

Pos.A Optional

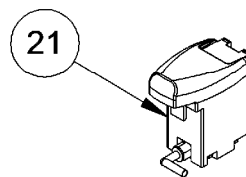
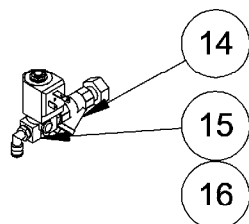

9.2.15 ACT 300 – 350 3phase Water Cooled

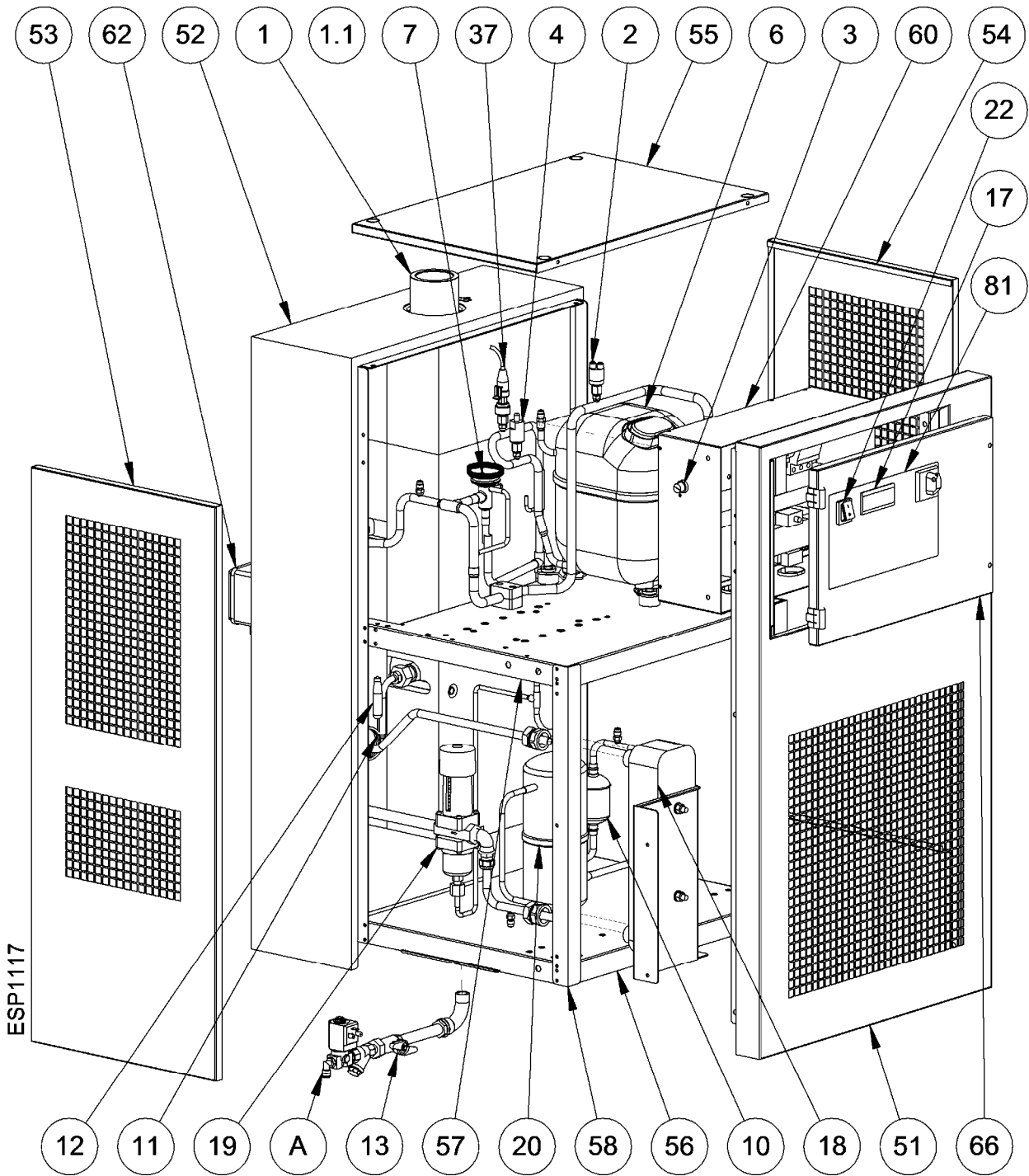

Pos.A Standard

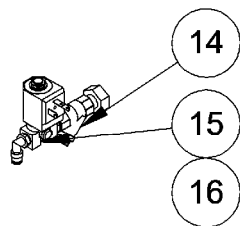

Pos.A Optional

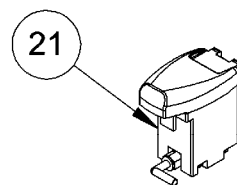

9.2.16 ACT 400 – 500 3phase Air Cooled

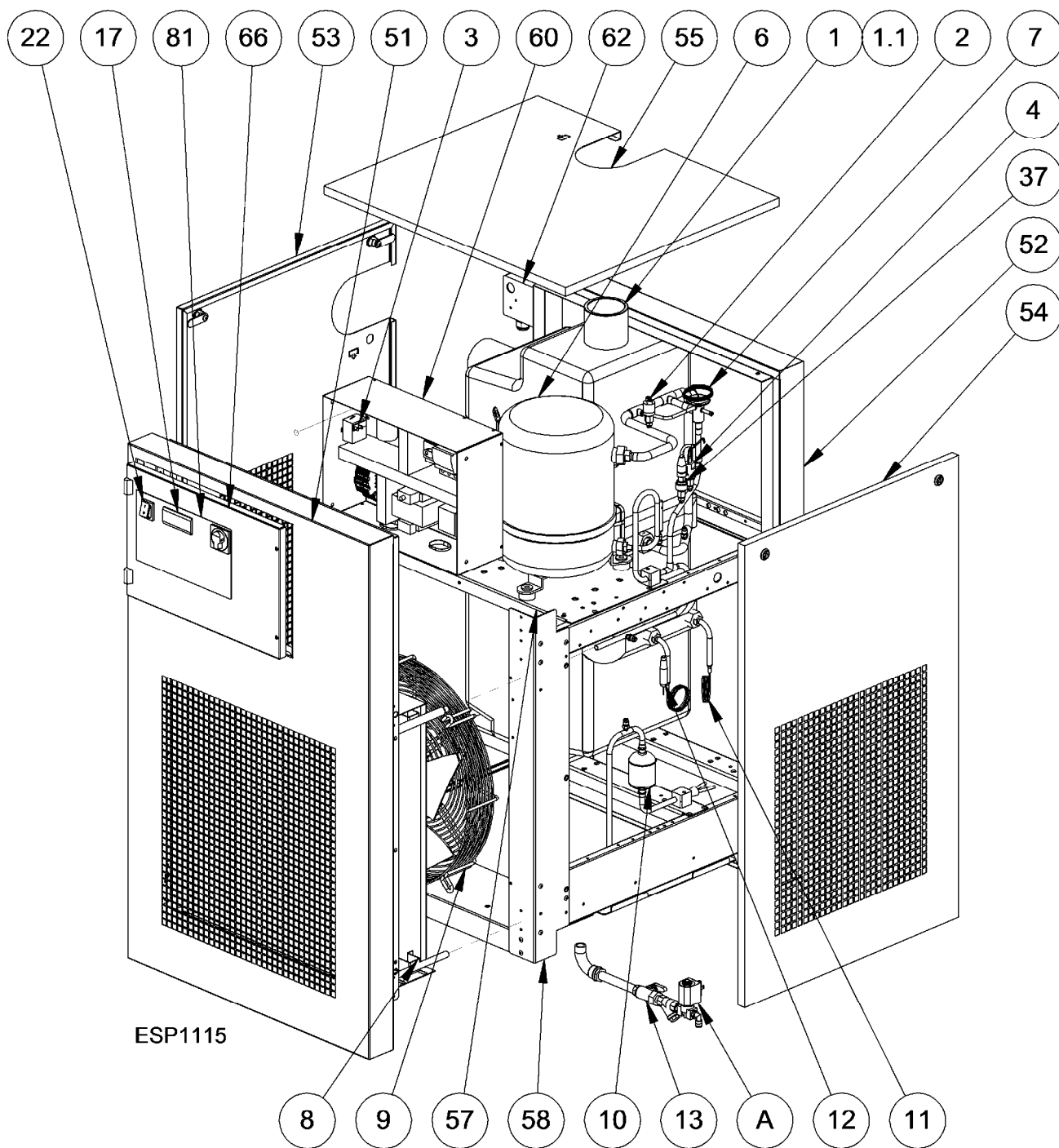

Pos.A Standard

Pos.A Optional

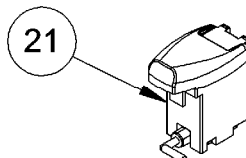
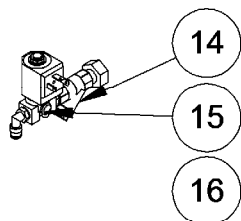

9.2.17 ACT 400 – 500 3phase Water Cooled

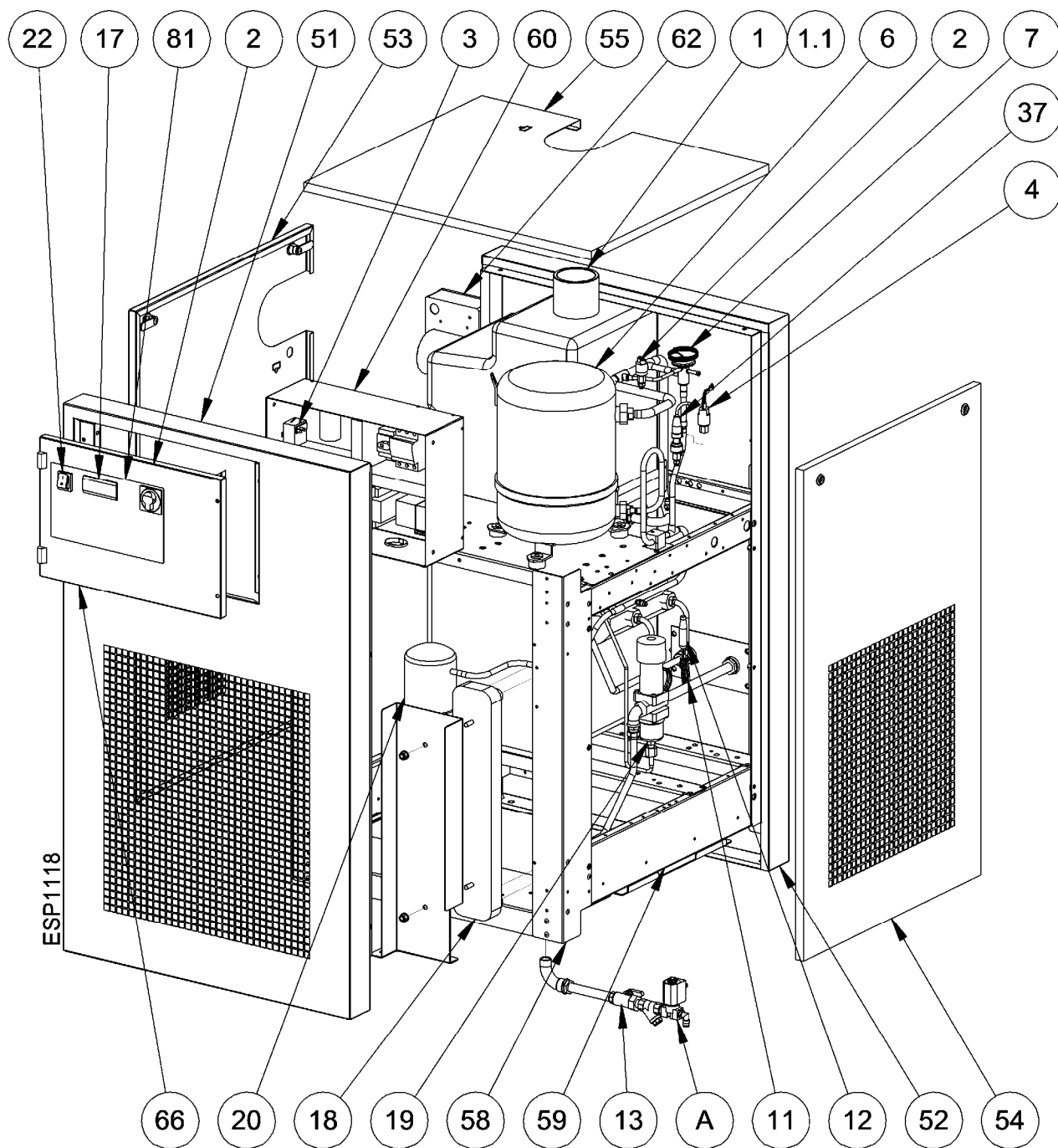

Pos.A Standard

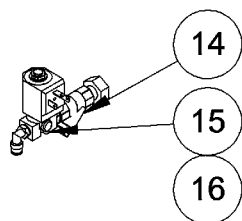

Pos.A Optional

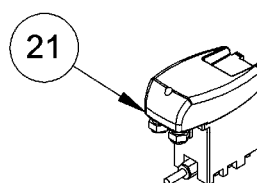

9.3 Electric diagrams

9.3.1 ACT 20 – 100

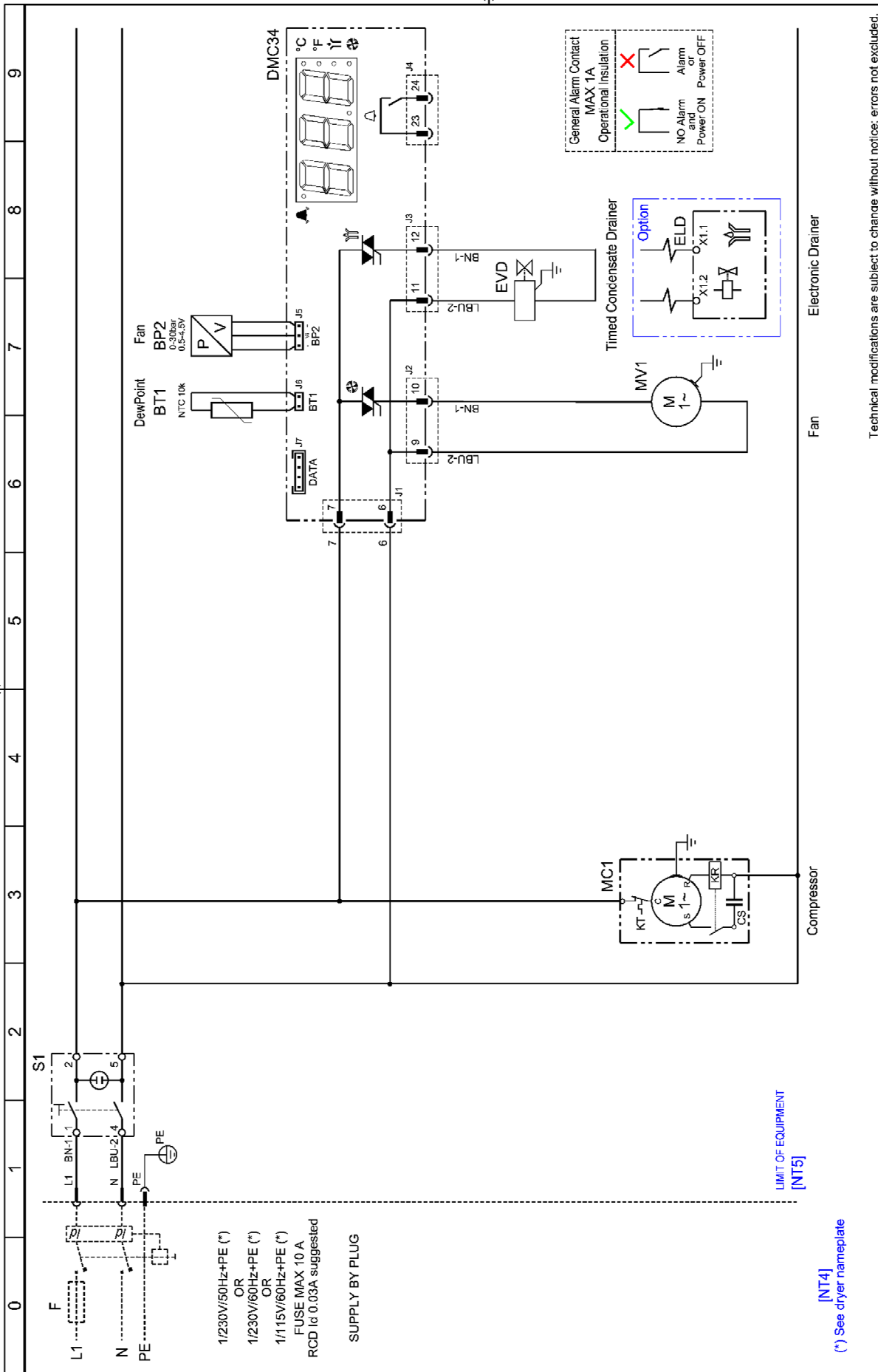

Technical modifications are subject to change without notice; errors not excluded.

Rev.

00

Drawing no. :

WD009_V00

Note :

Sheet 01 of 01

9.3.2 ACT 125 – 250

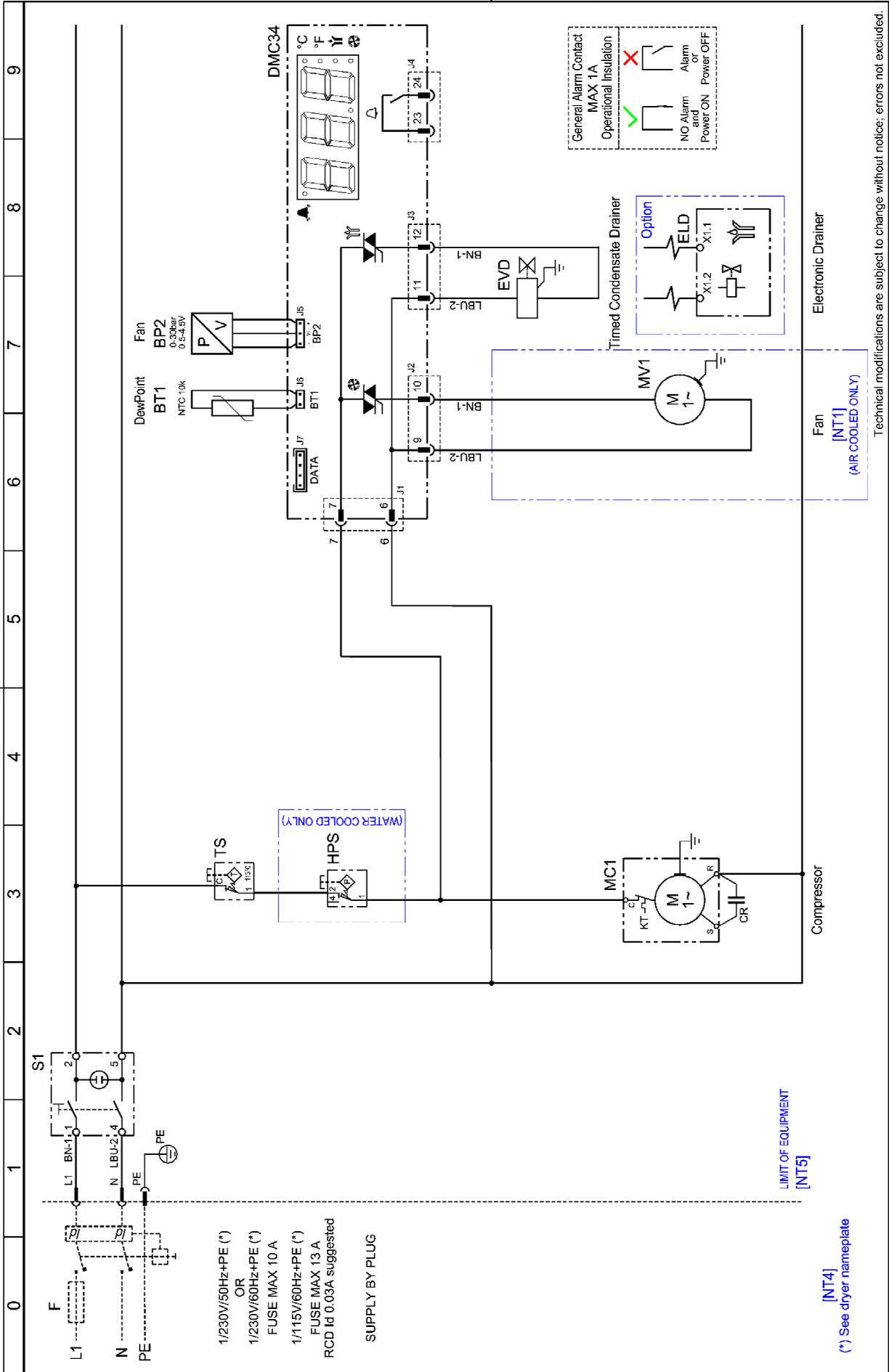

9.3.3 ACT 300 – 500

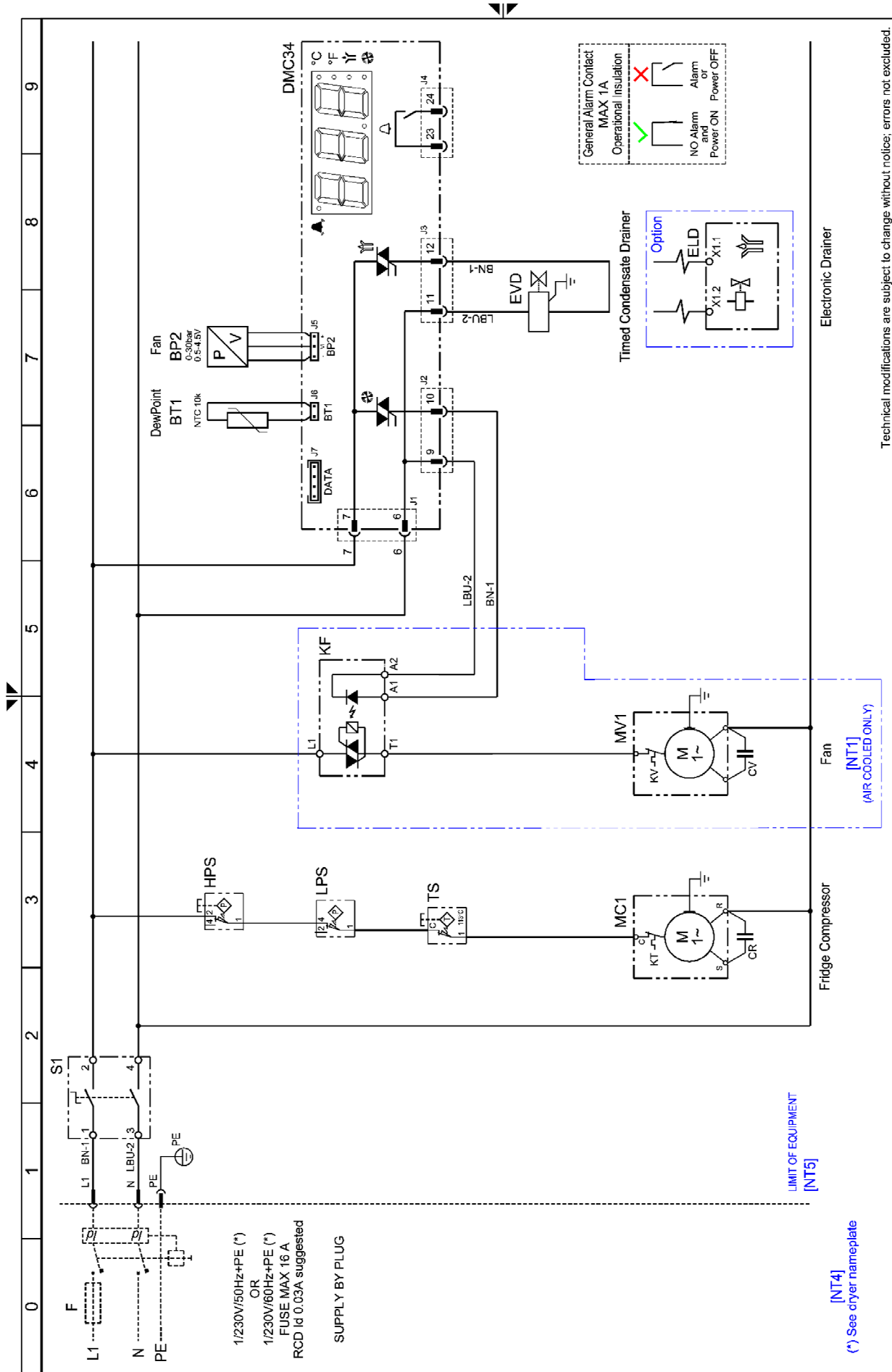

Technical modifications are subject to change without notice; errors not excluded.

Drawing no.: **WD012_V00**
 Rev. **00**
 Note: -
 Sheet **01** of **01**

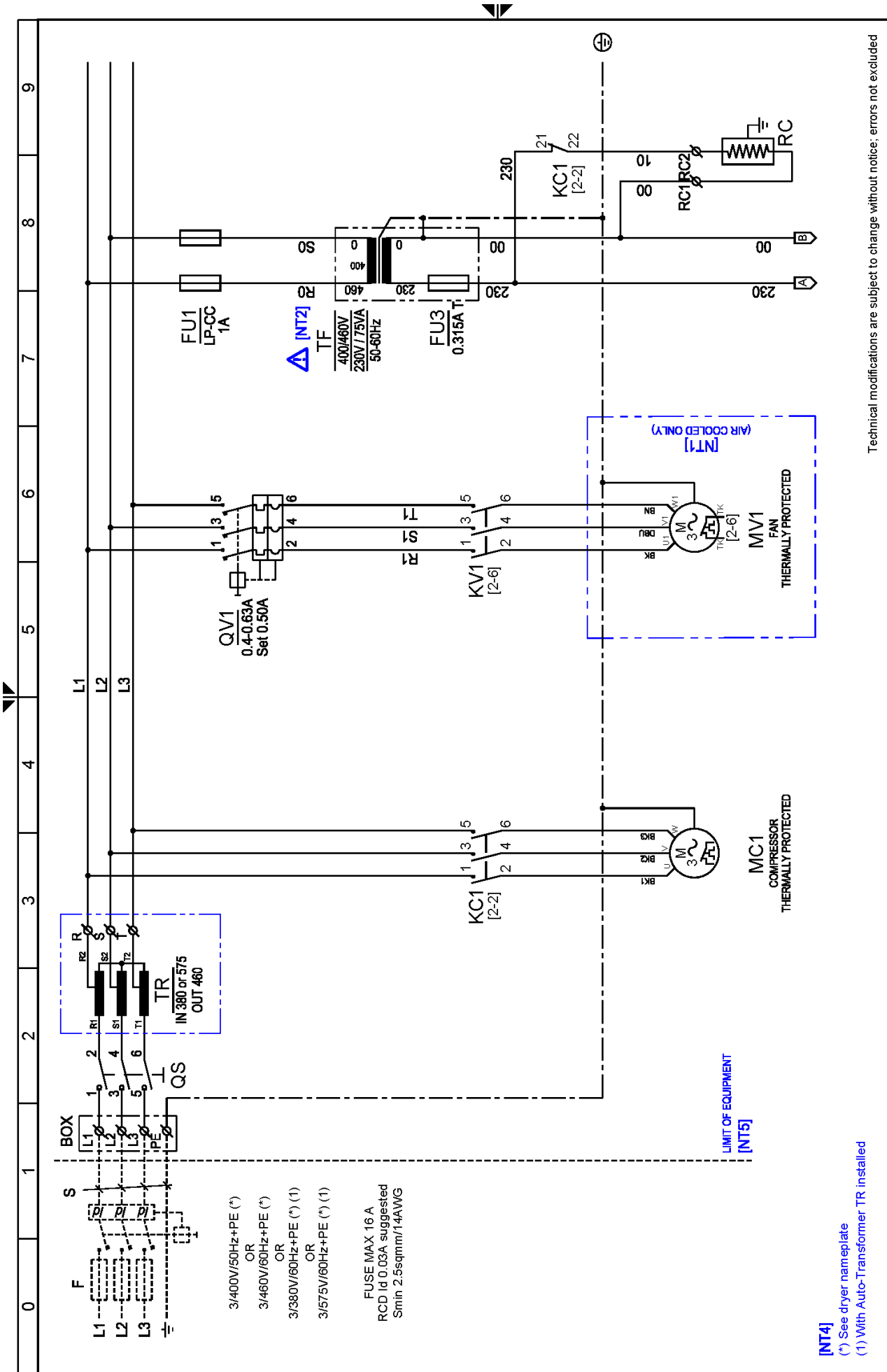

Technical modifications are subject to change without notice, errors not excluded

Rev.

00

WD5478QCD061A_V03

Note:

Sheet 01 of 03

9.3.5 ACT 200 – 500 3phase Sheet 2 of 3

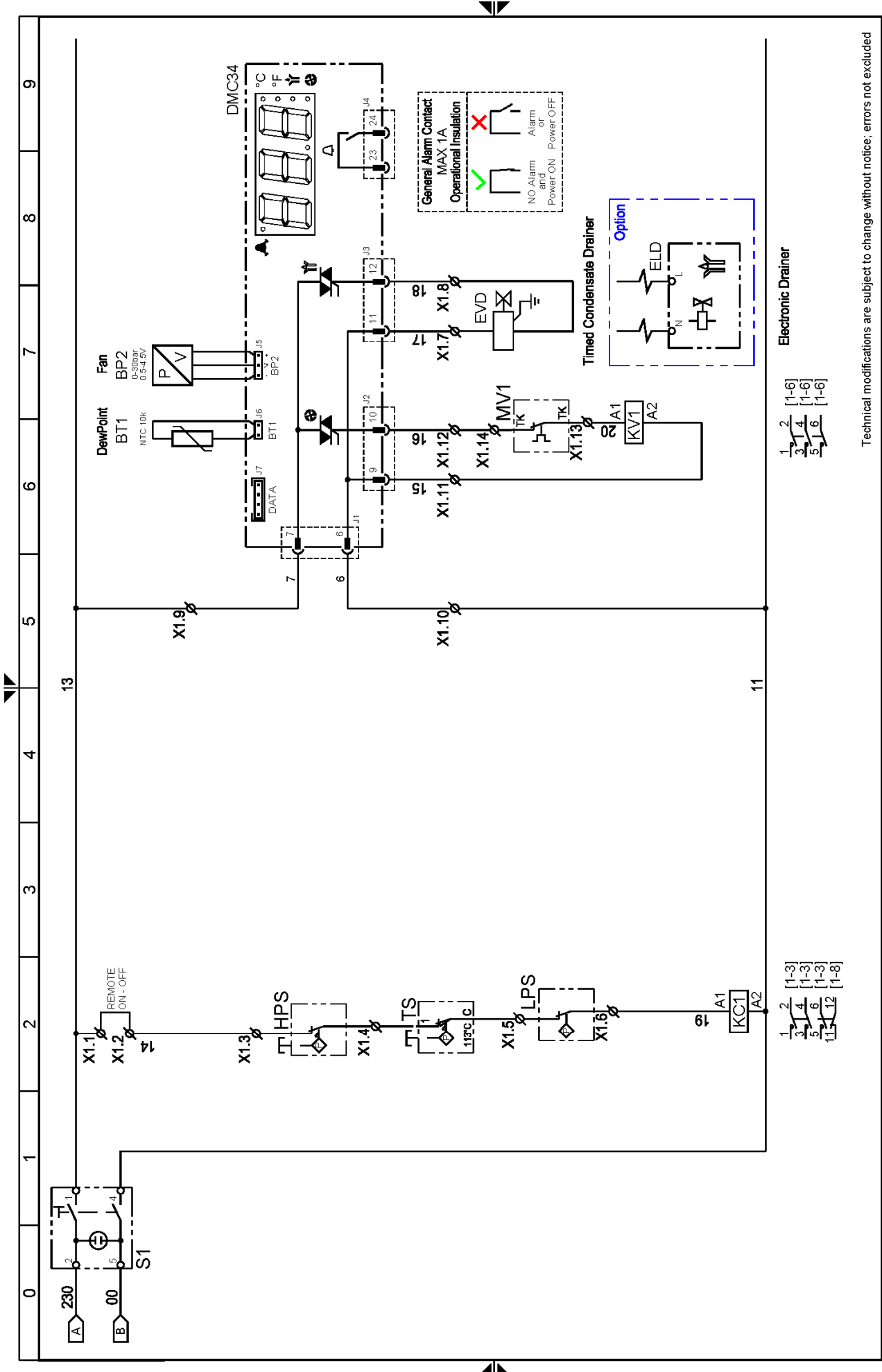

Technical modifications are subject to change without notice; errors not excluded

Drawing no. : WD5478QCD061A_V03

Rev. 00

Note : -

Sheet 02 of 03

9.3.6 ACT 200 – 500 3phase Sheet 3 of 3

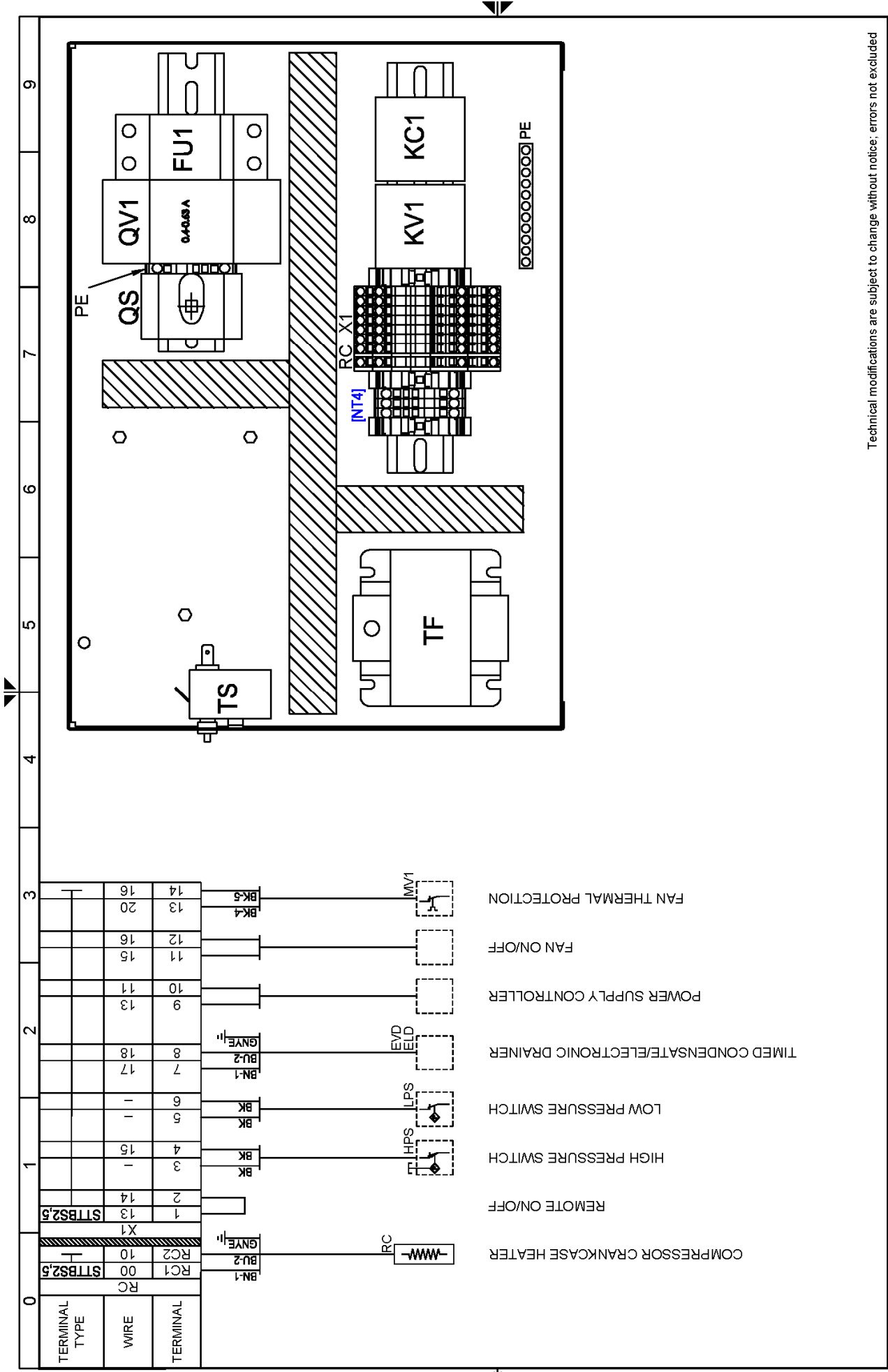

Technical modifications are subject to change without notice; errors not excluded

Drawing no.: WD5478QCD061A_V03 Rev: 00

Note: Sheet 03 of 03

10 Blank pages

COSTRUTTORE / MANUFACTURER :

FRIULAIR S.r.l.

Sede Legale:

34077 - Ronchi dei Legionari (GO) – ITALY
Via Joze Srebernic, 10
Cap.Soc. € 12.480 i.v.
P.IVA 00430110312
Export MGO001913
COD.ID.CEE IT 00430110312
R.E.A.GO n.51691
Cod.Fisc.e Reg.Impr. 00430110312

Sede Operativa:

33050 - Cervignano del Friuli (UD) – ITALY
Via Cisis, 36 - S.S.352 Km 21 Fraz. Strassoldo

www.friulair.com